

PACKET

STATUS

REGISTER



**Tucson Amateur Packet Radio Corporation**  
A Non-Profit Research and Development Corporation

**Fall 1996**  
**Issue # 64**

**Published by:**  
Tucson Amateur Packet Radio  
8987-309 E. Tanque Verde Rd.#337  
Tucson, AZ 85749-9399  
Phone: 817-383-0000  
FAX: 817-566-2544  
tapr@tapr.org  
www.tapr.org

**Office Hours:**  
Tuesday - Friday  
9:00am-12:00, 3:00-5:00pm Central

**In This Issue...**

TAPR's Statement on Spread Spectrum Technology Development.....	3
TAPR's Spread Spectrum STA is Granted .....	4
The Garmin GPS-20 as a Long-Term Clock.....	5
Linking BPQ Switches via Ethernet .....	6
TNOS Release 2.10 is Now Available .....	7
FCC Annual Report Goes On-line .....	7
Advanced Networking in Slovenia .....	8
TAPR at ARRL SW Division Convention .....	9
Silent Key: Joe Buswell, K5JB.....	9
Results of Packet Radio BBS Survey .....	10
ARRL and TAPR 1996 DCC.....	13
Banquet Speech by Lyle Johnson, WA7GXD..	19
One person's view of DCC '96.....	24
HF-SIG and the DCC.....	28
New Viterbi Decoder Release.....	29
Florida Packet Group.....	29
APRS Tracks: RELAY, WIDE and Other Paths	30
Keeping Electronics Cool in the Sun.....	31
Totally Accurate Clock (TAC).....	31
Some news from the WLAN front .....	32
WTB Announces Revisions to Web Pages.....	32
Grid Square Code.....	33
TAPR Group Purchase:	
PC-DSP and PC-SIM for Windows.....	33
Standardized Test Methods for Data Radios ...	34
TAPR Member's Mug.....	34
Organizational News.....	35

**President's Corner**

No long, lengthy diatribe from the president this quarter. With the first joint ARRL and TAPR Digital Communications Conference just wrapped up and me just a little behind with my PhD work, I'll fall back to the traditional organizational update and the presentation of the TAPR Position Statement on Spread Spectrum Technology Development.

The Position Statement is a major step forward on stating where TAPR plans to go now and in the future with regard to Spread Spectrum. The committee was formed at the Dayton Board of Directors meeting this past May and has worked on and off on the statement throughout the summer waiting for review and adoption at the Seattle Board meeting. The reason for this statement is that things are moving fast and are about to pay off in both equipment to use now and in the future for high-speed digital communications.

We should be announcing several major happenings next quarter, one of which should be the availability of Spread Spectrum (SS) 115Kbps radios. The real question becomes: do we operate these 115Kbps SS data radios under part 15 or under Part 97 or under a potential TAPR STA. We currently have a STA pending with the FCC, which we hope to have dislodged and operational by the next PSR. [Editor's note: The STA was approved just before press time, see the announcement elsewhere in this issue.] Our

**Look for TAPR at these Upcoming Events**

May 16-18, 1997 Dayton Hamvention

Packet Status Register  
Tucson Amateur Packet Radio Corp.  
PO Box 51114  
Denton, TX 76206-0114

SECOND CLASS  
POSTAGE PAID AT  
DENTON, TX.

ADDRESS CORRECTION REQUESTED

Member #: 201 Expiration: 1/1/97



Phil R. Karm (KA9O)  
7431 Teasdale Ave  
San Diego, CA 92122-2830

## President's Corner, continued...

attorneys are involved with getting the STA operational so we can bring this radio project on-line under amateur rules for operational testing and development. If not, then we can always operate them under Part 15. I guess it just baffles me that certain amateur elements would rather have us go off and operate under Part 15 or some other aspect of the FCC rules, instead of trying to help advance the radio art and operational skills under Part 97. Sometimes, I just want to give up and spend money on things that don't seem like sink holes; however, we will continue to shovel money into the beltway and will continue to budget money now and in the future for legal action on the matter. It was obvious last year that intelligence, knowledge, effort, money and lots and lots of time were going to be required to have any real advancement in the SS rules for either data or voice operations. The future looks bright, but the toll could be a steep one for everyone that wants to participate in this mode.

Anyway, I hope you enjoy reading the statement. Please feel free to write me or anyone on the board about it and let us know what you think.

As to the 1996 DCC, it was great! One of the best I think, although I'll defer to those few that have made almost all of them. Anyway, I think we set a very good trend for the future of the joint conference. Long-time attendees to the conference were more than thrilled to have Rod Stafford, KB6ZV, President of the ARRL, attend the conference. We believe this was the first time that the President of the ARRL was in attendance. Thanks for attending, Rod; we hope that we didn't overwhelm you with all of our enthusiasm in the area. Lyle Johnson, WA7GXD, gave one heck of a banquet talk. Lyle summed up in about 20 minutes what several of us take two or three hours to state. With luck, a transcription of the talk will be printed in this issue. The student papers were excellent! Thanks to co-chair Gerald Knezek, KB5EWV, co-chair Robert Diersing, N5AHD, and Frank Bauer, KA3HDO for making the first year possible. If you know a student, keep the travel award in mind for next year. Thanks to all those who presented in the Introductory Track. Especially Frank Perkins, WB5IPM, who with about 5 minutes notice filled the hole in the track that I had forgotten to fill after the initial presenter was not able to attend. Great job Frank! I would like to thank Keith Justice, KF7TP, for the work he did organizing the paper session. Also, a big thanks goes to Maty Wienberg at ARRL HQ for her work on the proceedings, which reliable sources inform me that she has done since the first one! Also, the biggest thanks to Steve and Tina Stroh. Without their help locally as the co-hosts, this conference would not have happened in the style that it did. Steve spent many long nights during the conference making sure that workshop materials were copied and making runs to Radio Shack, and Tina ran the

Entire contents Copyright © 1996 Tucson Amateur Packet Radio Corp. Unless otherwise indicated, explicit permission is granted to reproduce any materials appearing herein for non-commercial Amateur publications provided that credit is given to both the author and TAPR, along with the TAPR phone number (817-383-0000). Other reproduction is prohibited without written permission from TAPR.

Opinions expressed are those of the authors and not necessarily those of TAPR, the Board of Directors, Officers, or the Editor. Acceptance of advertising does not constitute endorsement, by TAPR, of the products advertised.

Postmaster: Send address changes to TAPR, P.O. Box 51114, Denton, TX. 76206-0114. *Packet Status Register* (ISSN 1052-3626, USPS 005-419) is published quarterly by the Tucson Amateur Packet Radio Corporation, 1418 Ridgecrest, Denton, TX 76205. Membership in Tucson Amateur Packet Radio, including a subscription to *Packet Status Register*, is \$20.00 per year in the U.S. and possessions, of which \$12.00 is allocated to *Packet Status Register*. Membership is \$20.00 in Canada and Mexico, and \$25.00 elsewhere, payable in U.S. funds. Membership and *Packet Status Register* cannot be separated. Second-class postage paid at Denton, TX.

### PSR Editor:

Bob Hansen, N2GDE  
P.O. Box 1902, Elmira, N.Y. 14902-1902  
Internet: psr@tapr.org

### Advertising:

Contact the TAPR office.

### TAPR Officers:

President Greg Jones, WD5IVD  
Vice President John Ackermann, AG9V  
Secretary Steve Stroh, N8GNJ  
Treasurer Jim Neely, WA5LHS

### TAPR Board of Directors:

Board Member	Term	Internet
Greg Jones, WD5IVD	1997	wd5ivd@tapr.org
John Koster, W9DDD	1997	w9ddd@tapr.org
Mel Whitten, K0PFX	1997	k0pfx@tapr.org
John Ackermann, AG9V	1998	ag9v@tapr.org
Barry McLamon, VE3JF	1998	ve3jf@tapr.org
Jim Neely, WA5LHS	1998	wa5lhs@tapr.org
Steve Bible, N7HPR	1999	n7hpr@tapr.org
Bob Hansen, N2GDE	1999	n2gde@tapr.org
Gary Hauge, N4CHV	1999	n4chv@tapr.org

Date is expiration of term on Board of Directors.

The Tucson Amateur Packet Radio Corporation is a non-profit scientific research and development corporation [Section 501(c)(3) of the U.S. tax code]. Contributions are deductible to the extent allowed by U.S. tax laws. TAPR is chartered in the State of Arizona for the purpose of designing and developing new systems for digital radio communication in the Amateur Radio Service, and for disseminating information required during, and obtained from, such research.

### Article submission deadlines for upcoming issues:

Winter 1997	January 7, 1997
Spring 1997	March 15, 1997
Summer 1997	June 15, 1997
Fall 1997	September 15, 1997

### Submission Guidelines:

TAPR is always interested in receiving information and articles for publication. If you have an idea for an article you would like to see, or you, or someone you know, is doing something that would interest digital communicators, please contact the editor so that your work can be shared with the Amateur community.

The preferred format for articles is plain ASCII text; the preferred graphic formats are HPGL or PCX. However, we can accept many popular word processor and graphic formats. All submissions on diskette should be formatted for MS-DOS.



hospitality area nearly single-handed and seemed to be able to feed an army, if we had had one there :-)

TAPR activities at Dayton 1997 are already in the first stages. If you have suggestions for programs during the Friday forum or a possible banquet speaker — let us hear. Suggestions are what make the Dayton event very positive.

TAPR began to process the latest GPS-20 order at the end of September. Units should have been out the door by the first of October, since we had to wait on the power connector parts. As soon as we have sold the 20 or so units remaining, we will start yet another collection of 100 units to ship. If you want a GPS-20 for the future TAC kit, there is time to get those orders in when you can. As soon as we get another 80 or so, we will place another order of 100.

While I write this, we are taking the last of the EVM56002 orders. What a ride! Looks like we will sell all 200 units in just a little over a month's time. Thanks to all those who purchased a unit. With this under our belt and continued communications with the DSP folks of Motorola in Austin, we should be doing other things in the future in this area. Keep an eye on the *PSR* and the TAPR-BB announcement list. Discussion is currently happening about doing a radio interface board for the upcoming Motorola EVM56303 board. This is one hot processor board. Something to look forward to next year sometime.

Talking about DSP, we still need another nine (9) orders on the PC-DSP software package. I'll make sure we have a reprint again in this issue. We have to have 21 purchasers to make the group buy. This is an excellent set of programs for DSP development.

As of October, TAPR has a new Secretary for the organization. Steve Stroh, N8GJN, will be taking over for Gary Hauge, N4CHV. Gary had expressed the desire at the Spring board meeting that if anyone else wanted to be Secretary, he was open to allowing them. Gary has done a terrific job since 1993 as Secretary. Thanks Gary. Steve, brings a lot positive energy to the board. In addition to his Secretary position, Steve will be working on a proposal on how regional organizations can be affiliated with TAPR. There has also been interest in looking at building better communications on an international level. Steve will be working on both of these issues. Welcome aboard Steve. Until next quarter, when I should have a little more time to write something in depth :-)

Cheers - Greg

## **TAPR's Statement on Spread Spectrum Technology Development**

TAPR was founded in 1982 as a membership supported non-profit amateur radio research and development organization with specific interests in the areas of packet and digital communications. In the tradition of TAPR, the Board of Directors at their Fall 1995 meeting voted that the organization would begin to actively pursue the research and development of amateur radio spread spectrum digital communications. At the Spring 1996 board of directors meeting, the following statement of purpose was passed:

TAPR believes that the technical facts support our conviction that conventional and spread spectrum systems can coexist without detriment to conventional systems on all frequencies from MF to EHF. To this end, TAPR will begin to research spread spectrum systems that will develop technology for future deployment.

As stated above, the TAPR board feels strongly about TAPR's focus on spread spectrum technology and especially how it relates to the potential coexistence on frequencies that will have increased number of users occupying them. The amateur radio bands, like other spectrum will become more heavily utilized in the future. It is in the interest of amateur radio to develop systems that are interference-resistant while not interfering with other primary or secondary users on those frequencies.

TAPR understands the concerns many have with the new technology, and believes that efforts in both education and research is necessary in order to allay the fears about interference and to demonstrate the benefits of the technology.

TAPR believes that today's communications technology is moving toward all digital transmitters and receivers. These advances in technology, combined with the swift evolution of cell-based transmission and switching protocols, are opening up a new set of possibilities for unique new services utilizing intelligent networks. These will contain smart transmitters, receivers, and switches. Today's Internet is perhaps the best example of a self-regulating structure that embodies these new technological approaches to communications in the networking domain. However, to date, many of these innovations have not moved into the wireless networking arena. TAPR will work on moving these innovations into the amateur radio community.

TAPR feels that the VHF/UHF/SHF radio networks of the future will involve a mixture of links and switches of different ownership, which terminate at the end-user via relatively short-distance links. What will then be required is a built-in, distributed, self-governing set of protocols to cause the network's behavior to make more efficient use of a limited, common shared resource, the radio spectrum. Creating such a self-regulating structure for the optimal sharing of spectrum will require much effort.

One of the major problems which stands in the way of these new approaches today is the current FCC regulatory environment and the manner in which spectrum is managed and allocated under its rules.

Historically, the current regulatory approach to radio has been based upon the technology that was in use at the time that the Communications Act of 1934 was framed, basically what we would call today, 'dumb' transmitters speaking to 'dumb' receivers. The technology of that time required reserved bandwidths to be set aside for each licensed service so that spectrum would be available when needed. Given this regulatory approach, many new applications cannot be accommodated since there is no available unallocated spectrum to 'park' new services. However, given the new set of tools available to the entrepreneur with the advent of digital technology, what once were 'dumb' transmitters and receivers can now be smart devices which are capable of exercising greater judgment in the effective use and sharing of spectrum. The more flexible the tools that we incorporate in these devices, the greater the number of uses that can be accommodated in a fixed, shared spectrum.

Therefore, TAPR will focus its spread spectrum effort in the following areas:

- TAPR will work to promote rules and technologies to make the most efficient use of the spectrum through power control, forward error correction, and other means to minimize interference among spread spectrum users and existing communications systems.
- TAPR will work on issues and efforts with other national organizations to change the regulatory environment and rules in order to promote the experimentation, development, and later deployment of spread spectrum technology.
- TAPR will work to develop information on the topic to help educate members and the amateur community as a whole about spread spectrum technology, and to disseminate this information via printed publications, the World Wide Web, presentations at conferences and meetings, and other means.
- TAPR will work to foster experimentation, development, and design of spread spectrum systems, and to facilitate the exchange of information between the researchers and other interested parties.
- TAPR will work to develop a national intra-network to foster the deployment of future high-speed spread spectrum systems into regional and local communities, including the development of suitable protocols and guidelines for deployment of these systems.
- TAPR will work with commercial companies who manufacture spread spectrum devices which operate in spectrum shared by the amateur radio service (ARS), in order to make them more aware of the nature of ARS operations on those bands with the goal to work towards the deployment of devices which will minimize interference between all spectrum sharing partners.

- TAPR will work with commercial companies who manufacture spread spectrum devices in order to identify equipments that can be either used or modified for use for Part 97 operation.

Adopted by the TAPR Board on September 20th, 1996 at Seatac, WA. Board of Directors Meeting.

Spread Spectrum Statement Committee:  
Greg Jones, WD5IVD  
Dewayne Hendricks, WA8DZP  
Barry McLamon, VE3JF  
Steve Bible, N7HPR

(Check [www.tapr.org/ss](http://www.tapr.org/ss) for full details)

---

## TAPR's Spread Spectrum STA is Granted

On November 8th, 1996, the FCC granted a Special Temporary Authorization (STA) to Greg Jones, WD5IVD, and Dewayne Hendricks, WA8DZP, on behalf of TAPR, regarding spread spectrum communications. On April 10th, 1996, TAPR requested a waiver of the rules and regulations governing Amateur Radio spread spectrum communications in order to conduct an experimental program to test spread spectrum emissions over amateur radio frequencies on different bands.

Briefly, the STA includes waivers for the following sections of Part 97:

97.119(b)(5) — Do not require CW or phone emission identification for SS emissions.

97.305(c) — Allow transmission of SS emissions on 50-54 MHz, 144-148 MHz, 219-220 MHz and 222-225 MHz.

97.311(c) — Allow hybrid SS emissions.

97.311(d) — Allow other spreading codes.

Full details on the TAPR spread spectrum STA are available on its web page <http://www.tapr.org> under the Spread Spectrum area.

A Special Temporary Authorization (STA) is the authority granted to a permittee or licensee to permit the operation of a broadcast facility for a limited period at a specified variance from the terms of the station authorization or requirements of the FCC rules applicable to the particular class of station.

TAPR plans to continue its leading role in developing standards and technology for spread spectrum communications for the amateur radio community through discussion groups, cooperative efforts, and experimental programs such as the one now being permitted by this STA. In particular, due to the rapid development of communications hardware and software, TAPR believes that the use of hybrid spread spectrum emissions, as well as spreading codes not envisioned by Section 97.311(d) of the Rules can be employed without causing harmful interference to other amateur radio operators.

## The Garmin GPS-20 as a Long-Term Clock

Tom Clark

As a follow-up to the initial testing of the timing performance of the Garmin GPS-20, I have continued the GPS-20 vs. ONCORE-based TAC for the past 2 weeks. As a reminder, for these tests I'm using an HP53131 counter logging the individual 1/sec time intervals measurements and letting the 53131 average the timing into 100 second bins. Every 100 seconds, the 53131 sends the mean/max/min/RMS values for the preceding window on its RS232 printer port and these are logged with PROCOM running in a DOS window in W95 on my P133 computer. I have written a couple of simple utilities to filter the raw log files suitable for analysis and plotting using EXCEL. Because the Garmin receiver 1PPS signal is ~2 usec early, the ONCORE TAC was offset by 10 usec to produce positive time intervals ~8 usec. The filter program subtracts this intentional offset so that the resulting values are correct. The GPS-20 is running in "2D" mode with the height constrained to the best average for my location, and both the GPS-20 and the ONCORE share a single antenna.

Because 2 weeks of 100 second data has nearly 12000 100-second bins and EXCEL can only plot 4000 point arrays, I did a quick filter program to combine 6 100-second averages into a single 10 minute (600 sec) average. This filter did some simple data sanity checks to make certain that the logged data is OK. These tests require that the raw measurements from the counter all lie within +/- 2 usec of "truth" and that the RMS of the internal average is better than 1 usec. When these tests fail, the entire 10 minute window is discarded and a new 10 minute window is begun.

The results of this 2 week run (with 1935 individual data points) are summarized in the plots gar-long.ps and gar-long.gif in the file

<ftp://aleph.gsfc.nasa.gov/GPS/totally.accurate.clock/gar-long.zip>

These plots are similar to the those posted earlier. Centered on the mean value -1.89 usec are the 10-minute averages (in blue) with the max/min individual 1 second measurements about 0.5 usec on either side (in red/green). The RMS deviations of the 600 points making up each 10 minute bin (typically 200-300 nsec) are at the top of the plot. An inset in the plot shows the histogram of the 10 minute averages (in 50 nsec-wide bins) between -2.5 and -1.4 usec.

The plots include some brief gaps which are (a) at the seams between different log files or (b) when one of the "data sanity" checks described earlier showed that

something was bad in the data. Between the gaps, the filter program found the data to be continuous.

The GPS-20 shows period of several days (like from 7/14 thru 7/16) when it runs very smoothly and predictably. Then it abruptly (like late 7/12 and late 7/19) it jumps by ~1 usec to a new value where it runs smoothly for period of hours to more than a day.

The original receiver data was not logged, so the explanation of the jumps is not known, but I suspect that they occur when the GPS-20 spontaneously reset itself. I have seen a number of times when the GPS-20 is tracking several satellites fine and for no apparent reason drops lock for 1-21 seconds and reports zero satellites in lock. Clearly future work is needed to develop "red warning flag" tests so that the user will know that timing is less than perfect.

The effect of ~1 usec jumps is clearly seen in the histogram. The long runs of the "upper" state give a peak centered at ~-1.75 usec but the less frequent "lower" values give rise to a flat pedestal (from -1.85 to -2.45 usec) that biases the average offset to be -1.89 usec.

The extreme range of any given 1PPS pulse around the mean is only ~2 usec wide and the range of averages is about 1 usec wide. Therefore if the user is content with a one microsecond clock accuracy, the GPS-20 is adequate. For higher accuracies, I would recommend the use of a better (and more expensive) receiver like the Motorola ONCORE.

For users who want to time-lock a fairly good crystal oscillator to GPS, let's examine the implications. Assume that the crystal is oven controlled and has an intrinsic stability of  $\sim 1:10^8$ . Timing derived from the crystal oscillator would drift by

$$\begin{aligned}(10^{-8}) * t &= 860 \text{ usec in one day} \\ &= 100 \text{ usec in 3 hours} \\ &= 36 \text{ usec in one hour} \\ &= 600 \text{ nsec in one minute} \\ &= 10 \text{ nsec in one second}\end{aligned}$$

The Garmin GPS-20 used as a clock produces timing that can be trusted at the +/- 500 nsec level so GPS starts "winning" at about 1 minute. If the oscillator is slowly steered with loop time constants ranging from minutes to hours, the  $1:10^8$  crystal will achieve long-term stability at the  $1:10^{10}$  to  $1:10^{11}$  level, comparable to the performance of a Rubidium standard.

[Note: If a better quality oscillator (like a laboratory-quality crystal or a Rubidium standard) is used with a GPS receiver like the ONCORE, and the "handover" time constants in the lock loop are set to be several hours, Cesium-like performance at levels like  $1:10^{12}$  can be achieved.]

## Linking BPQ Switches via Ethernet

Bill Barnes, N3JIX  
Internet: n3jix@mail.csrlink.net  
WWW: <http://acwww.bloomu.edu/~wlbarn>  
Packet : n3jix@n3jix.#lyc.pa.usa.noam

### Summary

With two or more computers, running G8BPQ node software, there is a need to link all these switches together. There are two options to do this: a 9600 baud RS-232 KISS port, or an ethernet port. BPQ wrote a driver for ODI that will allow the switch to talk to ethernet. This is a description on that process.

### What is ODI?

ODI is Novell's newest idea for clients. Before, when you changed cards, you had to change IPX versions as well. Also, that old IPX wasn't as "flexible" on card settings either. So, Novell decided to make a flexible IPX, and well, it grew way over that, into ODI. What ODI allows is card manufacturers to write a driver for their card, and use a generic IPX. So, the only thing that needs to be changed is the card driver and edit the appropriate section in the NET.CFG file.

ODI depends on a Link Support Layer or LSL. This file, LSL.COM, always needs to be loaded first.

Here is a diagram of how ODI works, and how G8BPQ's driver fits in there. Does that make any sense? No? Well, the idea is that many network cards can talk to LSL, and many protocols can talk to LSL. So LSL is like a translator.

### Ok, Here's how to make it work.

Run BPQCFG, try the drivers by hand, and make sure they work before rebooting. The most common problems are wrong settings for the network card in the NET.CFG or something spelled wrong in NET.CFG.

### Where to Get it

G8BPQ version 4.08a is available from the TAPR ftp server at:  
[ftp://ftp.tapr.org/tapr/software\\_lib/switch/bpq408a.zip](ftp://ftp.tapr.org/tapr/software_lib/switch/bpq408a.zip)

### My AUTOEXEC.BAT:

```
@echo off
prompt $p$q$g
cd\network
lsl          ; LSL is always needed first.
ne2000       ; This is your card driver.
cd\bpq
odidrv 125   ; This is your External ODI drv for BPQ.
              ; 125 is the Intlevel from your Ports section.
bpqcode      ; Of course, BPQCODE and anything else
              ; you may need to load.
cd\
ipxodi       ; IPX is only needed for Novell. Optional
              ; IPXODI needs to be loaded after ODIDRV
              ; to Avoid Lock up problems later.
```

### My NET.CFG:

```
Link Driver NE2000      ; Your driver section.
PORT 280                ; Your I/O address for card.
INT 12                  ; Your IRQ address for card.
FRAME Ethernet_802.2   ; Frame for Novell. (Optional)
FRAME ETHERNET_II      ; Frame for BPQ.
PROTOCOL IPX 0 ETHERNET_802.2 ; Needed for Novell(opt.)
PROTOCOL BPQ 8FF ETHERNET_II ; Needed for BPQ
BPQPARAMS              ; BPQ Driver info
ETH_ADDR FF:FF:FF:FF:FF:FF
                        ; ETH_ADDR Set to broadcast, to sense all nodes.
                        ; If you change it to the other card's ethernet
                        ; address, it should be faster, and
                        ; generate less traffic on a LAN. I use the
                        ; broadcast because the LAN is just for BPQ.
```

### My PORT section of BPQCFG.TXT:

```
PORT
ID=Ethernet Port
TYPE=EXTERNAL          ; This is an external driver
PROTOCOL=KISS          ; KISS or Netrom, both should work.
                        ; I tried KISS only.
INTLEVEL=125          ; (Note: 0x96=125)
; SPEED=9600           ; Should Not be needed.
; CHANNEL=A           ; Should Not be Needed.
QUALITY=203           ; Netrom quality for this port.
MAXFRAME=7            ; Send as many frames as possible because
TXDELAY=0             ; of a dedicated high speed link.
SLOTTIME=100
PERSIST=255           ; No need to wait for other stations
                        ; since we are a wire link.

FULLDUP=1
FRACK=7000
RESPTIME=100
RETRIES=10
PACKLEN=234
USERS=8
ENDPORT
```

The ODI drivers are available at:  
[ftp://ftp.novell.com/pub/updates/nwos/dscint12/vlmkt\\*.exe](ftp://ftp.novell.com/pub/updates/nwos/dscint12/vlmkt*.exe)

Where vlmkt\*.exe = vlmkt1.exe through vlmkt6.exe

These are the install disks for Novell DOS client.

## TNOS Release 2.10 is Now Available

Brian A. Lantz  
brian@lantz.com

YES, TNOS release 2.10 is available (or will be shortly) at the following sites:

sunsite.unc.edu in /pub/Linux/apps/ham  
ftp.mwmicro.com in /pub/mirrors/tnos/current  
ftp.lantz.com in /tnos/current

lantz.com is now a 56K link, but you may still get faster response from one of the first two sites.

MAJOR new features, such as the HTTP server, HTTP PBBS support, etc. Some of these are listed later.

The base docs. haven't changed. :-)

No diffs to patch against release 2.02 are available, as the diffs are larger than the source tree ;-)

No 'stock' MS-DOS executable zips are available as part of the official distribution, though there is a volunteer team (Team TNOS) that is ready to help those who are compiler-challenged with doing custom MS-DOS compiles. For info. on this, you will want to get the CUSTOMKT.ZIP, which includes the instructions and programs necessary to request custom compiles.

There is a file called "new2tn2.10" which contains info on all the changes to 2.10, the current Known Bug List, and the To-Do List.

ALSO: The WWW pages on lantz.com now have a point-and-click way to join one of the mailing lists maintained by lantz.com. Select 'mailing lists' from the main page and follow the 'listserv@lantz.com' link in the subscribe/unsubscribe sections, or go directly to it with:

<http://www.lantz.com/subscribe.html>

Enjoy.....

A brief summary of a FEW of the changes to TNOS 2.10:

- Added a 'sendmail' command, for sending quick notes from Command Session
- Added a HTTP server! (full featured, w/full Server Side includes)
- Added code to handle WORLI X-compressed forwarding protocol
- Added a completely configurable WWW interface to the PBBS
- Added a 'etc/reject.dat' file, like FBB's 'reject.sys' file
- Added a 'warnings' command, to warn of missing vital commands
- Added a MAN Command Session command, to display manual pages

- Added code to scan R: lines of incoming messages for altered BIDs
- Added a PBBS 'bid' command (finds area contain message, by bid)
- More enhancements to the PBBS forwarding code
- Many bugs squashed
- Simplified compile setup, cleaner compile display
- Most all \*.c files LINT'ed
- And much more.....

## FCC Annual Report Goes On-line

This year, for the first time, the FCC's Annual Report can be accessed through the Internet. The public will be able to browse and download the report from the World Wide Web. The Report is on the FCC's homepage at: [http://www.fcc.gov/annual\\_report\\_95.html](http://www.fcc.gov/annual_report_95.html)

The online version of the annual report is another step forward in helping the public find FCC information.

Some of the ways people will be able to use this electronic report include:

- There are two different Tables of Contents — one which represents the Annual Report's actual TOC, and one in "bookmark" format. Bookmark format lets you keep the TOC on the screen while you navigate through the Annual Report. Both Tables of Contents are hot-linked to chapters, pictures and documents which are mentioned in the Annual Report
- The thumbnail view lets you view all the pages in the document. From the thumbnail view, you can go directly to selected pages. For example, if you see a graph that you want to examine closely, click on the thumbnail and go directly to that page. You can also zoom in and out to see the overview of a page or details of part of the page.
- Within the document, there are hot links to the FCC Internet site. For example, in the FCC Online section, there are hot links to the FCC home page, to each Commissioners' home pages and to the FCC home page.
- The online annual report hot links to referred documents. For example in the section on DITF, there are hot links to the NOI on Closed Captioning, the NPRM on Hearing Aid Compatibility, and to the DITF Home Page.
- You can conduct word searches on the entire contents of the Annual Report.
- The online version prints out pages exactly as they appear in the printed version.
- There are online post-its to give explanations and help in how to navigate through the report.

## Advanced Networking in Slovenia

Iztok, S52D, WU2D, OK8ANP  
ham: S52D@S50BOX.SVN.EU  
ham: s52d@ljutcp.hamradio.si  
qrl: Iztok@mobitel.si

Hello friends !

High speed packet has been in use for quite some time in Slovenia. Here is a description of our projects, and pointers for more information. The main message is that megabits/sec on packet are simple and affordable using HAM technology — we intentionally omitted all nice features found on commercial systems with 100+ engineer years in development. We have MHz available: there is no need to watch every Hertz. We can do HOME-MADE radios: let's do it! We are not obligated to use standardized and approved technologies: let's try our own ideas! We can use simple technology: let's trade the last few decibels for simplicity and robustness.

All mentioned systems were designed by Matjaz Vidmar, S53MV. Most of the active S5 packeteers contributed their share in building the network.

In 1989 we built our backbone using 23cm radios, wide bandwidth FM (200 kHz) and 38.4 kbit/s manchester code. This design is now obsolete, (it was based on even older 23cm transverter). There were several redesigns in Italy and in Croatia. We do not suggest that you copy our design, we abandoned it because 38.4k is too slow for today. We have already started on a new design. Make a 23cm FM radio, put a ceramic FM filter in it instead of a crystal one, ignore NBFM stability problems and radio is as cheap as a narrow band FM!

There is a user 70cm WBFM radio, (200 kHz wide bandwidth FM), which exists in several incarnations: basic XTAL one and S51RM/S53RM redesign with PLL. Schematics are available in postscript format for FTP. It is based on cheap material in Slovenia (one TV company went QRT, so we got plenty of material). This radio is a big success: home made XTAL version can be built for US\$ 100, and manchester modems are as cheap as a 3105 chip alone. There are over 200 pieces built and operating in S5,9A,I,T9, HA and OE. Radios are robust and simple, so even non-experienced users can build them. Getting on 38k4 packet in Slovenia is as cheap as 1200 bps, if a TNC and 144 MHz handie are used for 1200 bps. To keep TXDELAY low, low AF is filtered out so radios are NOT to be used with G3RUH modems.

With medium-speed users it was necessary to upgrade the backbone. 1.288 Mbit/sec 13 cm PSK links were built a year ago, and they perform extremely well. Complete design is shown on our http page, including PSK modem and scrambler. It is not intended for beginners — we are

using it only for hops between mountaintop nodes. They are in use in S5 and in Italy.

Users shall build 23cm 1.288 Mbit/sec radios. This design is simpler than 13cm. We expect heavy users with clear path to local nodes to migrate from 70cm to 23cm next year. S57BBA is still scanning the pictures, so only english description is available on our home page. Some 20 radios are already built or in the final stage, and they perform well. *[Designs and descriptions for both of the above radios are available in the 15th Annual ARRL and TAPR Digital Communications Conference proceedings.]*

### Digital side

SuperVozelj node was developed based on a 68010 CPU. 68020 version is QRV, and we hope to migrate design to 68360 soon. Complete schematics and (rather old) sources are available for FTP.

Baycom USCC card was cloned with manchester modems by S51RM/S53RM. This is now main card to run 38k4 and 76k8 bit/s on 70 cm WBFM.

S57MMK and IV3ZXF both made SCC cards with DMA. Both are in alpha phase, and both run 1.288 Mbit/sec AX.25 packet on PC. Slightly tuned PI-card drivers are used for S57MMK card.

Last new add on is CDD camera on SV node. It is nice to check WX on hilltop by downloading pictures from a node. This shows ATVers what their future is... who needs MHz?

There are several voice-mailboxes in Slovenia. DVMS is designed by DL9MHZ. Voice-BBSes are controled by DTMF, and they are linked over packet. Messages up to 100 kbytes are exchanged between DVMS (Digital Voice Mail System) using packet.

So far, we are only discussing live voice over packet. It is no fun, so nobody really started it. Maybe on some boring winter weekends we can merge Soundblaster GSM compression sources and TFKISS driver.

### Availability

All projects are published in Slovenian in CQ ZRS magazine. Address:

ZRS (Slovenian HAM union)  
Lepi pot 6  
SI-1000 Ljubljana  
Slovenija

Some articles were published elsewhere, in Italy Germany (Weinheim conferences) etc.

We (frankly, S57BBA who is sysop of ljutcp.hamradio.si) are working on scanning all picture



and slowly translating texts to English, so all articles should appear there.

Check our URL <http://www.hamradio.si/hamradio> for progress. 13 cm PSK radio page is complete. There are some nice pictures of sysops and built hardware.

Some files of interest are available for anonymous FTP from JNOS box: [ljutcp.hamradio.si](ftp://ljutcp.hamradio.si)  
It is heavily loaded JNOS, so it is often QRT.

directory s5\_intro:

Oreadme.txt	
1m2bitqr.txt	first 1.2 Mbit/sec QSOs
how2use.sv	how 2 use SV node
net23cm.txt	old text file
pcb.arj	may be some PCBs ??
prmaps5.gif	packet map of Slovenia
sv72.m68	SV sources in Motorola format
sv72.asm	same in S53MV format
wb.txt	
wb.arj	PS files for 70cm WBFM radio and SV
wbfm-sch.arj	similar

Please note: These are HAM and Hobby projects. It is fun building a network, but it is not fun copying and mailing articles. All PCBs are available here, but it is not easy to send abroad: Our bureaucracy asks us to fill up zillion of papers for such mail. Also, due to small quantities, PCBs are expensive here. There is no serious attempt to make boxes commercial — designs would not pass type approvals. However, it is exactly what HAM rigs should be: experimentation, self education etc.

My personal opinion is that all our projects are worth checking, but radios should be redesigned locally to match material available, skills available and estimated number radios to be built.

What we shown is that HAMs can build a cheap and fast network, and that Megabits/sec over radios is not some distant future.

---

## TAPR at ARRL SW Division Convention

Keith Justice, KF7TP

TAPR was represented by a booth and talks at the ARRL Southwest Division in Mesa, Arizona, October 11 - 13. TAPR went "home" to Arizona to help welcome near-record numbers of hams to the exhibition hall and lecture rooms. Bob Myers, W1XT, Convention General Chairman, said attendance at the program presentations was the best in recent years.

The TAPR booth was staffed by members Keith Justice, KF7TP; Daniel Meredith, N7MRP; and Jim Wortham, W7GNP. Keith also gave TAPR-sponsored talks on "Introduction to TCP/IP" and "Commercial Radios for Packet Radio." Daniel gave a talk on "Introduction to Packet Radio" also under TAPR sponsorship.

---

## Silent Key: Joe Buswell, K5JB

It is my sad duty to report the death of Joe Buswell, K5JB on Thursday, 29th of August. Joe was extremely active in many phases of amateur radio and most recently was truly an Oklahoma pioneer in the realm of packet and other digital forms of amateur communication.

Joe was one of the very first (if not THE first) amateur on packet in the state of Oklahoma. He had run a Packet BBS on an old Apple 2 computer for many years. This was the FIRST packet BBS in Oklahoma. He was the state coordinator for TCP/IP addresses. He operated SEVERAL VHF and UHF packet and TCP/IP forwarding links and was one of the truly knowledgeable individuals regarding various versions of the NOS digital communications software programs.

Joe had been a mainstay for many years of the Oklahoma Traffic and Weather Net on 3900 kHz each weekday afternoon. He was similarly active on the Oklahoma Phone and Emergency Net which is conducted on the same frequency on Sunday mornings. Joe and other gurus of digital communication within Oklahoma and some surrounding areas also had an informal info. net on 3883 kHz every Saturday morning. Joe had provided technical expertise and advice for many years to the Oklahoma Repeater Society Inc (ORSI) and had done the same for even longer to the informal group which was the predecessor of ORSI.

I had known and worked very closely with Joe on various aspects of amateur radio for almost 25 years. It is extremely hard for me on a personal basis, to say nothing of the amateur radio aspect, to realize that I have lost another good friend. Few amateurs are aware of it, but Joe was an accomplished guitarist, who played professionally during the 1960s at local coffee houses. On several occasions, Joe, I, and a few other local hams who had a bit of musical inclination gathered at my home for some pickin', grinnin', laughin', and drinkin'. Joe had played with John Denver back when he was still John Duesseldorf. I wish that we could have gotten together for more of those good times. So long, old friend. May your new QTH always have good propagation, reliable power, and bug-free software.

73 de Mac  
K2GKK @ K2GKK.#OKC.OK.USA.NOAM

# Results of Packet Radio BBS Survey June - September 1996

Marty Albert, KC6UFM  
marty@trucom.com  
KC6UFM@KC6UFM.#SEMO.MO.USA.NOAM

The survey consisted of 12 questions. In addition to the replies themselves, there was also information gathered both by the Internet survey page (through HTML and JAVA coding) and on the Packet Radio network.

This report is grouped into four topics:

- (1) Reply Data
- (2) Answers
- (3) Other Information Gathered
- (4) Overall Comments

## Section 1 - Reply Data

### Number Of Replies:

I received replies to the survey as follows:

Internet = 397 ( 81.19%)  
Packet = 91 ( 18.61%)  
US Mail = 1 ( 0.20%)  
TOTAL = 489 (100.00%)

### Number Of Duplicate Replies

There were a number of duplicates received as follows:

Internet = 4 ( 22.22%) from 2 respondents  
Packet = 14 ( 77.78%) from 5 respondents  
US Mail = 0 ( 0.00%) from 0 respondents  
TOTAL = 18 (100.00%) from 7 respondents

(NOTE: Duplicates were handled by taking only the most recent copy and discarding the older replies.)

### Discarded Replies

Other than duplicates, the following is a summary of discarded replies due to inability to read the replies:

Internet = 0 ( 0.00%)  
Packet = 1 (100.00%)  
US Mail = 0 ( 0.00%)  
TOTAL = 1 (100.00%)

### Comments

As can be seen, the vast majority of replies were via Internet. I found this interesting for two reasons: (1) The survey was about Packet Radio and I would have expected more interest than was shown by the Packet community, and (2) There were two people on the Internet who were pushing very hard to have the survey available on Packet as they felt there would be a high response rate.

It is also interesting that there was a much higher number of duplicates sent by Packet users in terms of absolute numbers (14 vs 4); Percent of all duplicates (78% vs 22%); And percent of all replies (3% vs 1%). It should be noted that the Packet duplicates had different BIDs (all appeared valid) and dates from their respective PBBS. Also, the Packet duplicates had different answers. I frankly was expecting more duplicates from the Internet HTML version of the survey... Since this was a form type response, it would have been easier both to make an error and to just re-submit the survey. On Packet, users had to actually write a reply message and send a Packet message, a much more difficult process!

The only discarded reply looked to have been trashed by HF forwarding stations between the US and Western Europe. This one reply represents only 0.20% of the total and so has little impact on the survey.

Please see the *Other Information Gathered* section for additional details that are of interest.

## Section 2 - Answers

This section will look at each question and the answers received.

The format for each question will be the same:

- Question Statement
- Answers and number of replies
- Discussion

### 1. What Packet BBS program do you use now, or if you are planning to set up a BBS in the future, what BBS program are planning to use?

F6FBB	103	( 21.06%)
WORLI	26	( 5.32%)
AA4RE	21	( 4.29%)
MSYS	73	( 14.93%)
DOS/Windows NOS	75	( 15.34%)
Unix/Linux NOS	29	( 5.93%)
APLink	2	( 0.41%)
CBBS	0	( 0.00%)
G1NNA	0	( 0.00%)
SV7AIZ	0	( 0.00%)
TheBox	16	( 3.27%)
UFQBBS	0	( 0.00%)
WA7MBL	1	( 0.20%)
WinLink	7	( 1.43%)
XOBBS	0	( 0.00%)
Other	22	( 4.50%)
None	114	( 23.31%)
TOTAL	489	(100.00%)

It should be made clear that these numbers are based only on replies to the survey and not on actual distribution of the various software. In other words, there very likely are many more people using a particular software package than what is shown here.

It is assumed that the NONE answer are those that do not now and do not plan to operate a PBBS. This was a failure in the survey structure in that such an answer should have been available while, in fact, it was not.

In any event, two trends are clear: (1) F6FBB is the single most popular PBBS program and (2) The various NOS systems are, when totaled, even more popular.

### 2. How long have you operated a Packet BBS?

Less than 1 year	46	( 9.41%)
1-2 years	82	( 16.77%)
2-3 years	74	( 15.13%)
3-5 years	58	( 11.86%)
More than 5 years	51	( 10.43%)
I don't run a BBS	178	( 36.40%)
TOTAL	489	(100.00%)

The main information from this question is that about 1/3 of all respondents are not PBBS SysOps. This is about what I had expected when this started.

One interesting fact is that over 40% of our BBSs have been around 3 years or less with nearly 10% less than a year old. This shows a fair growth rate and an attraction to new people to Packet.

### 3. If you are thinking of operating a Packet BBS, how long before you plan to put your BBS on the air?

Less than 6 months	38	( 7.77%)
6 months - 1 year	26	( 5.32%)
1-2 years	12	( 2.45%)
More than 2 years	3	( 0.61%)
I run a BBS now	309	( 63.19%)
I wouldn't run a BBS	101	( 20.65%)
TOTAL	489	(100.00%)

This question again confirms that about 2/3 of the replies were from current SysOps. We also note here that about 15% of all current users are planning to move into being s SysOp in the next 2 years or less.

**4. As a SysOp (or possible SysOp), what is the MOST important feature a BBS should have?**

Easy set up	36 ( 7.36%)
Easy day to day operation	58 ( 11.86%)
Lot of features	19 ( 3.89%)
Telephone modem support	4 ( 0.82%)
Good documentation	127 ( 25.97%)
Author support	71 ( 14.52%)
Lots of add-on programs	8 ( 1.64%)
TCP/IP support	55 ( 11.25%)
Variety of TNCs supported	2 ( 0.41%)
I'm not a SysOp	109 ( 22.29%)
TOTAL	489 (100.00%)

Little of this surprised me as I had expected that Documentation, Author Support, and Easy Operation would be of prime importance.

One thing worth noting is the desire for TCP/IP Support. However, taking this in light of the number of SysOps using a NOS variant, this is not at all unusual.

**5. As a SysOp (or possible SysOp), what is the LEAST important feature a BBS should have?**

Easy set up	18 ( 3.68%)
Easy day to day operation	21 ( 4.29%)
Lot of features	36 ( 7.36%)
Telephone modem support	41 ( 8.38%)
Good documentation	4 ( 0.82%)
Author support	1 ( 0.20%)
Lots of add-on programs	92 ( 18.81%)
TCP/IP support	36 ( 7.36%)
Variety of TNCs supported	129 ( 26.38%)
I'm not a SysOp	111 ( 22.70%)
TOTAL	489 (100.00%)

The correlation between this question and Question #4 is good. Again, there were no real surprises here to me.

**6. As a Packet User, what is the MOST important feature a BBS should have?**

Good HELP systems	142 ( 29.04%)
ANSI support	25 ( 5.11%)
Other graphics support	42 ( 8.59%)
TCP/IP support	41 ( 8.38%)
Selective message reading	109 ( 22.29%)
File transfers	53 ( 10.84%)
White Pages support	47 ( 9.61%)
Multiple languages	9 ( 1.84%)
Other	21 ( 4.29%)
TOTAL	489 (100.00%)

I found two surprises here to my own preconceptions... (1) The relatively high number of users wanting file transfers (nearly 11%); and (2) The very low number of people wanting multiple language support (under 2%).

**7. As a Packet User, what is the LEAST important feature a BBS should have?**

Good HELP systems	22 ( 4.50%)
ANSI support	61 ( 12.47%)
Other graphics support	106 ( 21.68%)
TCP/IP support	87 ( 17.79%)
Selective message reading	25 ( 5.11%)
File transfers	27 ( 5.52%)
White Pages support	29 ( 5.93%)
Multiple languages	101 ( 20.65%)
Other	31 ( 6.34%)
TOTAL	489 (100.00%)

**8. What type of network support is MOST important built into a BBS?**

TheNET/NetROM	183 ( 37.42%)
ROSE	14 ( 2.86%)
TCP/IP	161 ( 32.92%)

Other	29 ( 5.93%)
None	26 ( 5.32%)
I don't know	76 ( 15.54%)
TOTAL	489 (100.00%)

It should be no surprise that TheNET and NetROM support is the leader here with TCP/IP functionality a close second.

It is interesting that more people were in favor of no network support than for ROSE support. While in my local area, ROSE never did catch on, I was under the impression that it was quite popular in some places.

**9. What type of network support is LEAST important built into a BBS?**

TheNET/NetROM	27 ( 5.52%)
ROSE	231 ( 47.24%)
TCP/IP	8 ( 1.64%)
Other	114 ( 23.31%)
None	2 ( 0.41%)
I don't know	107 ( 21.88%)
TOTAL	489 (100.00%)

This question supports the opinion that TheNET, NetROM, and TCP/IP support are favored while ROSE is considered not important.

**10. If a Packet BBS that you really liked was available as a SHAREWARE program, how much would you pay for it?**

Less than \$10	86 ( 17.59%)
\$10 - \$25	74 ( 15.13%)
\$25 - \$50	38 ( 7.77%)
\$50 - \$75	23 ( 4.70%)
More than \$75	11 ( 2.25%)
I wouldn't pay	257 ( 52.56%)
TOTAL	489 (100.00%)

The results here are both surprising and a bit frightening. Please see Question 11 for more comments.

**11. If a Packet BBS that you really liked was available as a COMMERCIAL program, how much would you pay for it?**

Less than \$10	91 ( 18.61%)
\$10 - \$25	68 ( 13.91%)
\$25 - \$50	30 ( 6.13%)
\$50 - \$75	12 ( 2.45%)
More than \$75	4 ( 0.82%)
I wouldn't pay	284 ( 58.08%)
TOTAL	489 (100.00%)

The results from this question and Question 10 do not bode well for BBS authors and for any company that wishes to publish a BBS program. There is good correlation between the two questions with the Commercial replies being slightly lower than for Shareware.

Several comments from respondents stated that this is a hobby and/or this is Amateur Radio and no one should make a profit from the service. I wonder if this applies only to software or if Kenwood et.al. should not be selling radios?

The most frightening comments were several that stated that Hams are, in general, software pirates and that any Shareware or Commercial software would soon be spread world-wide to any Ham that would want it. One comment even stated that there is a "network" of Hams on the U.S. West Coast that regularly give away Commercial software.

**12. What operating system would you like to run a Packet BBS under?**

MS-DOS or clone	145 ( 29.65%)
Windows 3.1 or 3.11	111 ( 22.70%)
Windows 3.x with Win32s	8 ( 1.64%)
Windows 95	122 ( 24.95%)
Windows NT	12 ( 2.45%)
Unix or Linux	48 ( 9.82%)
Apple Macintosh	13 ( 2.66%)
Commodore Amiga	3 ( 0.61%)
Atari ST/TT	1 ( 0.20%)

Other 26 (5.32%)  
 TOTAL 489 (100.00%)

Sadly, I had overlooked OS/2 when the list was set up. I presume that OS/2 makes up at least a good part of the Other responses.

The surprising thing here is that most folks are still using DOS vs. a more sophisticated OS. With the availability of Windows 3.x, Win32s, Windows 95 and NT, and Linux offering more power and flexibility than DOS, one must wonder why so many are still using DOS. Perhaps this is related to the cost factors seen in Questions 10 and 11.

Also a bit surprising is the number of folks using a NOS variant and yet less than 10% are using Linux or Unix.

One thing that is clear is the relatively few people using some 680xx based computer. Only about 6% of all respondents use a non-Intel computer and OS.

### Section 3 - Other Information Gathered

This information, while interesting, does not really impact on the survey directly. Because of the nature of the supplemental data, it will be presented broken into two parts.

#### Internet Replies

Extra information from the Internet was gathered by means of JAVA, CGI, and HTML coding and found the following about respondents:

<b>OS Used</b>	
DOS	24.05%
Windows 3.x	55.22%
Windows 95	12.53%
Windows NT	2.11%
Unix	0.30%
Linux	2.08%
Macintosh	3.52%
Atari ST/TT	0.07%
Other	0.12%

<b>OS Reported CPU</b>	
8088/86	0.00%
80186	0.00%
80286	0.05%
80386	57.25%
80486	22.13%
80586	12.63%
80686	0.25%
68000	0.32%
68010	0.00%
68020	0.23%
68030	1.21%
Other	5.93%

<b>OS Reported Clock Speed</b>	
10 MHz	1.31%
10 - 20 MHz	16.58%
21 - 50 MHz	52.70%
51 - 75 MHz	19.22%
76 - 100 MHz	8.61%
101 - 150 MHz	1.13%
151 MHz	0.45%

<b>Web Browser Used</b>	
Netscape 1.x	11.03%
Netscape 2.x	18.66%
Netscape 3.x	0.23%
MS Explorer 1.x	13.62%
MS Explorer 2.x	9.51%
MS Explorer 3.x	0.58%
Mosaic Any	12.52%
Text Based	28.21%
Other	5.64%

Overall, this shows that survey respondents tend to use older computers (386 based) at relatively slow speeds (21-50 MHz) with Windows 3.x and a text based Web Browser.

This is a bit surprising to me... I had expected to see much more modern hardware in use.

#### Packet Replies

The only item to report here is that it took, on average, 16 days for a private packet reply to reach my station.

### Section 4 - Overall Comments

First of all, I want to thank all of those that took the time to reply to this survey. It has provided some good information that, if nothing else, will generate a few flames and heated discussions in the Packet community!

Because of the correlations of many questions, I feel that, for the sample group, the data appears to be valid.

A few general conclusions can be made:

(1) F6FBB software is the most popular single program, but the NOS variants are coming on very strong.

(2) Most of our PBBS stations have been in operation less than 3 years.

(3) SysOps want and need good documentation and author support.

(4) Users want and need good online help systems.

(5) TheNET and NetROM are by far the most popular networks but TCP/IP is gaining rapidly.

(6) Most SysOps will pay little, if anything, for BBS software.

(7) DOS continues to be the most popular OS for BBSs.

What does all this mean? Like any survey, that is a matter of interpretation of the data and has a large personal bias component.

In general, we must ask why the results are the way that they are...

Why do we have so many new BBSs on the air? Is it because the "old timers" didn't bother to answer? If so, why not? Is this reality? If so, what happened to the older stations? Does this relative lack of experience have any impact on the Packet network in general? Good? Bad?

Why the strong outcry for good documentation and author support? Do SysOps feel that they are not now getting this? If so, why not? Is this tied to the position that most will pay little for software?

Why the growth in NOS and TCP/IP? Are these systems better than what we have now or is this just a passing fad? What benefits does TCP/IP and NOS offer as compared to traditional BBSs and vice versa? Is NetROM and TheNET doing what we need to be done or are they just hanging on based on tradition or simple distribution?

Why do users ask for good online help? Are they not getting that from current BBS programs? Do current programs have online help that is not set up correctly by the SysOp? Is this tied to the SysOp desire for good documents?

Why do SysOps appear to be unwilling to pay for software? Does current Shareware work? How much have the several authors collected so far? Since this is Amateur Radio, should all software be free? What about hardware? Are there really groups of Hams that distribute pirate software or are respondents just blowing off hot air?

Why are so many Hams using DOS when more powerful OSs are available? Is this tied to the unwillingness to pay for software and/or the apparent use of older, low-end computers? Is this more a function of a lack of Windows and Unix based software for Ham use? Is this even a problem or concern at all?

I will leave the detailed interpretation of the data and the debate over its meaning to the masses. Please keep in mind that this is a VERY small sample and should in no way be taken to represent all Hams or even all Packet operators.

Again, thanks to those that answered the survey and thanks for reading these results.

## ARRL and TAPR 1996 Digital Communications Conference

Greg Jones, WD5IVD

The Digital Communications Conference was held on September 20-22 in SeaTac, Washington, between Tacoma and Seattle, Washington. The attendance count for the conference was 168 people. This was an increase of 30% from the previous year. It seemed that the conference was well rounded in technical content. When you talked to people after the conference, they commented that HF, DSP, Spread Spectrum, or APRS were the main areas of interest. The nice thing about this year's conference was that all of these and more were focused on at different times of the conference.

The conference was co-hosted by the Puget Sound Amateur Radio TCP/IP Group and Boeing Employees Amateur Radio Society (BEARS). If it were not for the effort of Tina and Steve Stroh, N8GNJ, of the Puget Sound Amateur Radio TCP/IP group many aspects of the conference would not have been possible. Tina and Steve put in a lot of work on the local issues before and during the conference. Both amateur radio groups contributed towards the very well provisioned hospitality suite.

### Friday, September 20th, 1996

The conference began on Friday with the opening of the hospitality suite, even though the TAPR Board and ARRL Future Systems Committee had already had meetings that day. As noted above, attendees visiting the hospitality/registration area had a good selection of munchies and drinks, plus lots of space to set up equipment and sit around and discuss projects and plans. Friday afternoon Keith Sproul, WU2Z, held an APRS workshop. 65 people attended the workshop and heard the latest on what Keith and his brother Mark, have been working on. After the workshop, people moved back over to the hospitality area.

### Saturday, September 21st, 1996

Saturday morning the conference got an early start at a little past 8:00am when Steve Stroh, N8GNJ, Rod Stafford, KB6ZV (President ARRL), Greg Jones, WD5IVD (President TAPR), and Keith Justice, KF7TP welcomed the conference attendees and kicked off the conference.

As a first ever, the conference audio from the main session was made available via RealAudio over the Internet — LIVE!. There were a few glitches throughout the day, but overall the comments received were positive. One of the first problems was that the local phone company (US West) had a switch problem that was not corrected until after 9am. The problem had been reported the night before! Once that was corrected, we had an error on the TAPR server that was corrected just after 10:30am. After these two small problems, the feed was pretty much continuous until the encoding



Keith Sproul, WU2Z, speaking during one of his many talks at this year's ARRL and TAPR DCC.

computer locked up a little past 4pm, when someone came by and decided they wanted to check their e-mail. The live broadcast had over 200 people connect to listen to the conference throughout the day.

If you couldn't attend the conference, TAPR is making all the main paper session presentations available on their web site ([www.tapr.org](http://www.tapr.org)) under the Virtual Conference page. The Introductory topic sessions were recorded, but due to local Part 15 device interference (from the several Metricom radios operating in and around the conference) a lot of the audio was lost due to noise hits, one of the problems you sometime run into with Part 15 wireless audio mics. Something for TAPR to fix next conference with better wireless mic devices. In addition to the audio, a full page of images from the conference is available for browsing.

At 8:30am the main paper sessions and the introductory sessions began. The first paper was "Baseband Group Delay Equalization of IF Filters for Data Communications" by Tom McDermott, N5EG. Tom

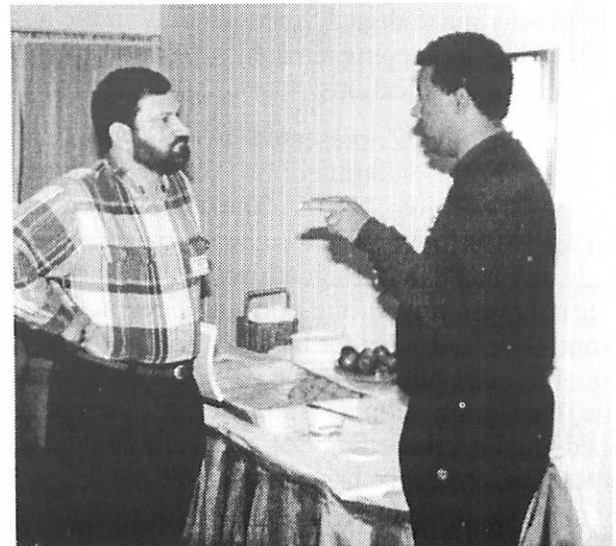

John Ackermann, AG9V, and Dewayne Hendricks, WA8DZP, have an informal discussion in the hospitality area.

talked about ways to figure IF filters in receivers. He examined some amplitude, phase, and delay properties of first-order, second-order, and all-pass filters. In addition, he showed several examples of Chebychev and Butterworth IF filters. A very good talk if you are interested about how to make modems work over radios. Much of the talk was based on information being published in Tom's book "Wireless Digital Communications: Design and Theory" being published by TAPR.



Dorothy Jones, KA5DWR (TAPR Office Manager), and Tina Stroh (Local Host) at the registration table in the hospitality area.

Paul Rinaldo, W4RI, followed Tom and presented a paper entitled "Amateur Radio Digital Voice Communications." However, Paul didn't talk about his paper. He focused his presentation on spectrum policy and current issues that are impacting amateur radio. A very interesting discussion touching on such things as current FCC policy and issues regarding the upcoming WRC. His paper in the proceedings outlined that amateurs need to apply the same energies and talents that made SSB, ATV, packet, and small satellites possible to now make digital voice a reality in the amateur bands. Nothing is keeping amateurs from implementing digital voice communications.

Keith Sproul, WU2Z, presented "A 9600 Baud modem for the LPT port." submitted by Wolf-Henning Rech, DF9IC, and Don Rotolo, N2IRZ. The talk outlined a simple modem for 9600 Baud FSK which can be connected to a LPT port that has been designed by Wolf-Henning Rech, DF9I. It is powered from the port and does not need any alignment. Several drivers for DOS and Linux are available because of its compatibility to the BayCom PAR96 modem (and its PacComm clones). The design was originally published in the proceedings of the 12th Internationally Packet Radio Conference Darmstadt, 1996.

Craig McCartney, WA8DRZ, then presented "Constructing a Worldwide HF Data Network." Craig discussed the design and implementation of a HF Digital system that his company had developed for the maritime

communications environment. Craig touched on some of the history and then explained the practical guidelines for making such a system work reliably. The system uses Automatic Channel Sounding, Clover, and they have adopted several different ways for interconnecting their worldwide sites together (dedicated dial up, Internet, and others). They should have 15 stations operational by the end of 1996.

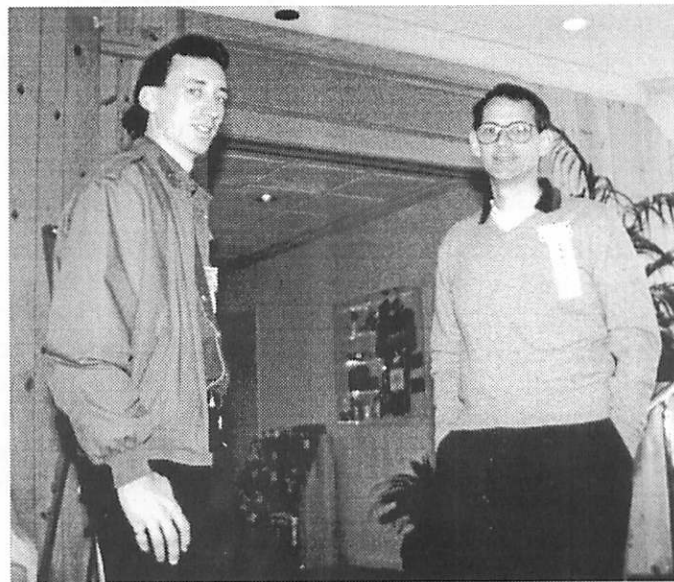

Tim Bagget, AA5DF, and Tom McDermott, N5EG outside the main paper session room. Tim and Tom both presented papers during the morning sessions.

The first introductory session had Greg Jones, WD5IVD, presenting a 45 minute talk on basic digital communications from an operations standpoint. Greg touched on HF, VHF modes as well as explanations of many of the topics that would be seen during the conference. The talk was very generic and tried to touch on a lot of basic topics. Johan Forrer, KC7WW, then presented an introductory talk on HF digital communications. Johan discussed in detail what was involved and how people operated the HF digital modes. He touched on basic and more advanced aspects of the HF digital communications modes. This was the second year that the DCC held an introductory topic session stream. These sessions ran in parallel with the main paper sessions in the adjacent room. The purpose of these sessions was to try to have a more in-depth look at specific topics of interest. Based on comments received as of this writing, the introductory session will be present again at the next conference.

Session 2a (10:30am) was started with a presentation by James Wagner, PhD, KA7EHK, entitled "Packet and Internet." James' paper looked at the recent debate issues concerning the question of BBS mail forwarding by methods other than the ham RF network. Whichever side proves to be "right," (and it is possible that both may be right), the answers to this debate will have an impact on all packet users. James discussed these issues and looked at both sides of the issue. He voiced the concern about



Craig McCartney, WA8DRZ, and Paul Rinaldo, W4RI, take a break outside the main session room after their paper presentations.

some of the deterioration of long-haul RF networking due to the ease of access and use of Internet and other wireline based systems.

Tim Bagget, AA5DF, presented a paper regarding the use of Motorola's DSP with regard to HF applications. This talk did not appear in the proceedings. Tim, a recent graduate from New Mexico State, is now working in Austin for Motorola in the DSP group. Tim focused on the DSP used within the Kenwood TS870. The TS870 uses two 56002 DSP and are in-line with the IF of the radio. The radio has 237 selectable IF filters! Tim discussed the implementation and some of the methods of implementation and also discussed the overall family of Motorola DSP processor line. The 56300 core was discussed in detail. The EVM56002 was discussed and Tim touched on the TAPR group purchase and possible future direction with EVM products for amateur applications.

James Wagner, PhD, KA7EHK, presented his second paper entitled "Strategies for Improving Wide-Area Networks." James' paper covered the topic that wide-area single-frequency networks still cover large areas of this country. While, this might be the low-end solution to networking, it doesn't seem to be going away. A number of strategies have been developed for improving such networks, but these strategies are very slow to be adopted. He discussed some of the reasons for the continued existence of these networks and the strategies and their likelihood of success. How can we use education to try to get changes made in different areas to help support better and faster communications. It was interesting to note some of the comments during the question period that indicated a number of new digital networks seem to be generating systems very similar to what was done in the mid-80's and thus we seem to have lost the link between those efforts 10 years ago and new operators today.

Session 2b of the Introductory Topic session saw presentations by Steve Bible, N7HPR, on Spread Spectrum Communications and Keith Sproul, WU2Z. Steve covered the basics and more advanced concepts of Amateur Radio based Spread Spectrum Communications. There was a lot of interest in this topic, as indicated by the number of people who couldn't find a chair to sit! The presentation touched on the upcoming directions of Spread Spectrum communications in Amateur Radio. All very exciting. Keith Sproul, WU2Z, presented a 45 minute condensed version of his normal APRS talk. He hit on all the major aspects of APRS and got to demo the system and his software one more time during the conference. If there had been a prize for most papers given and most equipment moved, Keith would have won it!

The conference then broke for Lunch. Lunch was a sandwich buffet. Near the end of Lunch, Rod Stafford, KB6ZV (President ARRL) and Gerald Knezek, KB5EWV (DCC Student Awards Co-Chair) presented the first annual Student Paper Awards. Rod and Gerald presented checks and plaques to Michelle Toon, KC5CGH, and Marc Normandeau. Michelle received the award for 'best educational or community-oriented application paper by a student' for the paper 'Circus of the Stars.'

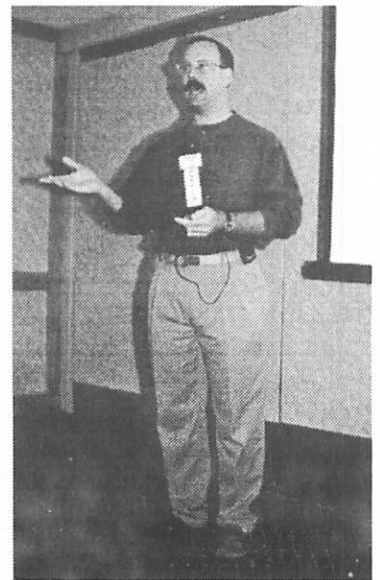

Steve Bible, N7HPR, presenting during his Introduction to Spread Spectrum talk.

Marc received the award for 'best technical/theory-oriented paper by a student' for the paper 'Object-Oriented Modeling of a Satellite Tracking Software.' This year's awards were made possible by a donation by the ARRL Foundation, Inc. It was very exciting to see the culmination of a year's worth of work. The principle individuals responsible for getting the Student Awards started were Gerald Knezek, KB5EWV, Robert Diersing, N5AHD, and Greg Jones, WD5IVD. They had wanted to do something like this for the last several years and found it possible now that the TAPR and ARRL conference have been joined. This made for a good opportunity, and the first round of results were very positive. Gerald and Robert will continue as co-chairs for the 1997 awards to be given at next year's DCC. Full details on the 1997 Student Paper Awards are already available on the TAPR web site, under the DCC link.



Rod Stafford, KB6ZV (President ARRL), Michelle Toon, KC5CGH, Marc Normandeau, and Gerald Knezek, KB5EWV (DCC Student Awards Co-Chair).

Session 3a (1:30pm) began with the two Student Award Papers. "Object-Oriented Modeling of a Satellite Tracking Software" was presented by Marc Normandeau and his professor M. Barbeau, VE2BPM. This paper won the category of Best Technical/theory-oriented Student paper. Marc's paper presents a case study of an object-oriented development of a satellite tracking software. It is designed following the Real-Time Object-Oriented Modeling (ROOM) methodology. The design resulting from the application of ROOM is implemented in C++ on the QNX platform. The QNX kernel is about 15K and is really fast! ROOM yields a modular architecture which is clear, reusable, and maintainable. Use of QNX leads to a highly performant and reliable system. Excellent presentation!

Michelle Toon, KC5CGH, then presented the paper entitled "Circus of the Stars." This paper won the category of Best Educational or Community-Oriented Application Student paper. Michelle described a unique collaboration between diverse groups in the Waco, Texas, area. The project uses amateur radio to tie school sites in the Central Texas area together during a mentoring session based on night-time astronomical observation. Michelle discussed the issues of amateur radio in education and the project of involving schools with amateur radio during this summer project. Michelle told a great story of the trials and tribulation from the first introduction of the concepts of amateur radio in education from classes held by Gerald Knezek, KB5EWV, at the Univ. of North Texas to her current efforts and projects in implementing various approaches. One of the best presentations during the conference.

Keith Sproul, WU2Z, then presented a paper by him and Mark Sproul, KB2ICI, entitled "WinAPRS: Windows Automatic Position Reporting System. A Windows version of APRS." WinAPRS is a Windows version of the popular APRS, Automatic Position Reporting System. WinAPRS is fully compatible with APRS, the DOS version, and MacAPRS, the Macintosh version. Due to the larger

amounts of memory available in the Windows operating system, WinAPRS, just like MacAPRS has many additional features not available in the DOS version. Keith discussed in detail some of the issues of supporting different OS software and how they have been able to do it easily.

Session 2b of the Introductory Topic session saw presentations by Glenn Elmore, N6GN, and Frank Perkins, WB5IPM. Glenn gave a presentation on High-Speed Networking which covered various topics in high speed digital communications. Glenn showed off what he has done the last several years as well as hit the high points regarding good network design and concepts. The session was well received. Frank Perkins presented a session on Satellite Communications. Due to a mix up, no one had been found to fill the slot of this talk, once it was known that the original speaker was not going to be able to attend. Armed with just blank overhead foils and a few pens, Frank, being a real trooper and an expert end user of amateur digital satellites, stepped right in and gave a very good talk. Frank covered the basics of getting on the digital satellites, talked a little about the upcoming Phase 3D, discussed a little DSP, and answered a lot of questions from the audience about the topic. This session ended the Introductory sessions, which seemed to be very well received by those attending the different presentations.

Session 4 (3:30pm) was kicked off by a paper entitled "javAPRS: Implementation of the APRS Protocols in Java," presented by Steve Dimse, KO4HD. Steve's paper described an implementation of the Automatic Position Reporting Systems (APRS) protocols in the computer language known as Java. javAPRS extends the usefulness of APRS to the Internet and allows animation of APRS tracking data live over Java equipped systems. Steve used javAPRS during his trip from Florida to Washington to allow all those on APRS SIG and others to watch his progress. Very exciting

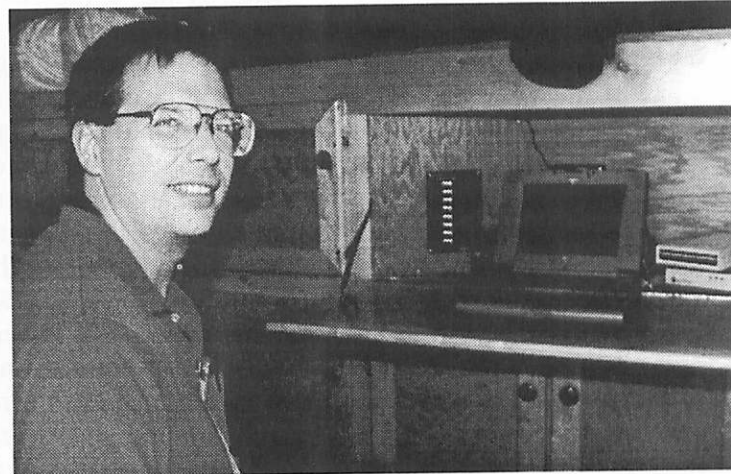

Steve Dimse, KO4HD, seen here inside his van equipped with APRS. Steve drove from Florida to Washington, and APRS devotees watched his progress via javAPRS



stuff. There is a link to his Web page from the TAPR SIG web page.

Keith Sproul, WU2Z, presented his last paper of the day entitled "Automatic Radio Direction Finding Using MacAPRS and WinAPRS." Basically, Keith described how radio direction finding had been around for almost as long as radio itself and with the assistance of new Doppler-based RDF systems with computer interfaces you could combine these elements under APRS. APRS now has the ability to display the RDF information on maps, giving the user a graphical way to view the RDF patterns. Using various CD-ROM databases and the like, tracking down potential jammers should be easy. Keith showed several examples to explain the concept and discussed some practical real stories. Keith felt that with all of the available technology, we should be able to develop a system that zeros in on a location and automatically shows us the possible transmitters in the area much simpler than any system has done in the past.

The last paper of the conference was presented by Phil Karn, KA9Q. Phil's presentation is not in the proceedings. Phil presented current information regarding his experimentation of coding and modulations on a PC. Some very exciting potentials Phil is seeing in this work. Everyone will need to listen to Phil's talk on the Internet to get all the details.

Dinner was held at 6pm. After dinner several Plaques were awarded. A plaque was given to Keith Justice, KF7TP, which read "TAPR Proudly Recognizes Keith Justice, KF7TP for outstanding service from 1993 to 1996 as a board member and Vice President from 1994 to 1995 of the Tucson Amateur Packet Radio Corporation." Another plaque was given to John Ackermann, AG9V, which read "TAPR

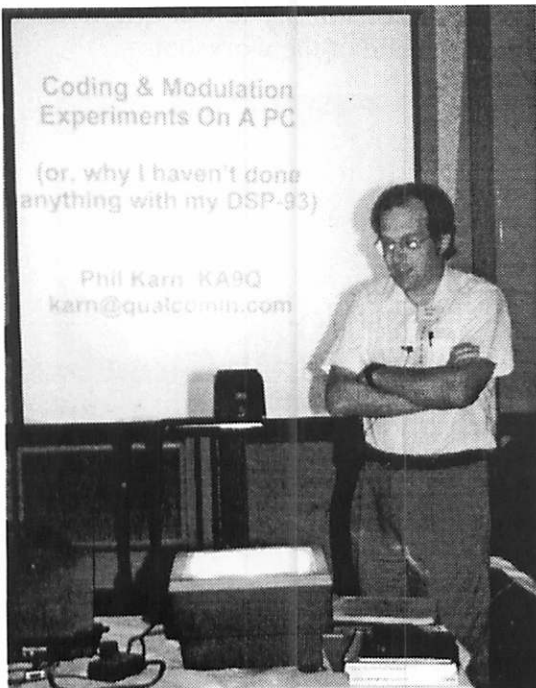

Phil Karn, KA9Q, presenting his experiments of coding and modulation on a PC

Proudly Recognizes John Ackerman, AG9V, for outstanding service to TAPR as founder of the TAPR NETWORK Special Interest Group in 1994 and dedicated volunteer." Then several awards were given to the local hosts of the conference. "ARRL and TAPR are pleased to recognize, Steve Stroh, N8GNJ, and Tina Stroh for their invaluable and dedicated service as local coordinators for the 1996 ARRL and TAPR Digital Communications Conference." "ARRL and TAPR are pleased to recognize Puget Sound Amateur Radio TCP/IP Group for their participation as local co-hosts for the 1996 ARRL and TAPR Digital Communications Conference." "ARRL and TAPR are pleased to recognize Boeing Employees Amateur Radio Society for their participation as local co-hosts for the 1996 ARRL and TAPR Digital Communications Conference." One plaque of special note was given to Lori Wienberg, which read "ARRL and TAPR are pleased to recognize Lori Wienberg in appreciation for invaluable and dedicated service and support to the Digital Communication Conferences." Lori has been doing the conference proceedings from the very beginning. Everyone who has ever read or gotten a DCC proceedings owes a big thanks to Lori. Thanks Lori!

After the plaques were presented, Lyle Johnson, WA7GXD, gave his banquet talk. The talk was a real winner! The transcript will be printed in this issue of the PSR. Take a minnute and read it. You can also listen to Lyle's talk on the TAPR web site, under the DCC link on the TAPR Home Page. Lyle talked about the future of Amateur radio and gave some analogies that hit the mark one after the other. Everyone went away after the banquet thinking about where amateur radio is today and where it might be going.

After Dinner, several activies began. The TAPR HF-SIG met, people gathered and held informal discussions in the hospitality area, and David Pederson, N7BHC, presented a slide show and talk on his work in getting digital communications set up in Africa.

At 8:30pm, TAPR's HF-SIG met. Johan Forrer, KC7WW, began the SIG meeting with an introduction to SIG activities and a list of current goals for the SIG. Tom McDermott, N5EG, then presented an overview of the physical effects of HF ionospheric propagation, what their effects are on an HF signal, how you simulate these effects for a modem, and concluded with information on CCIR-520. This was a very good technical presentation and really hit a lot of the most important aspects of trying to build an HF simulator. Building an HF simulator has been a goal of the SIG over the last year. Johan then showed the HF simulator that had been developed based on the theory in Tom's presentation. The simulator was running on a TAPR/AMSAT DSP-93. Having a common simulator that the group can agree on has been deemed necessary in order to test and compare results for future HF digital communications designs. Johan discussed the

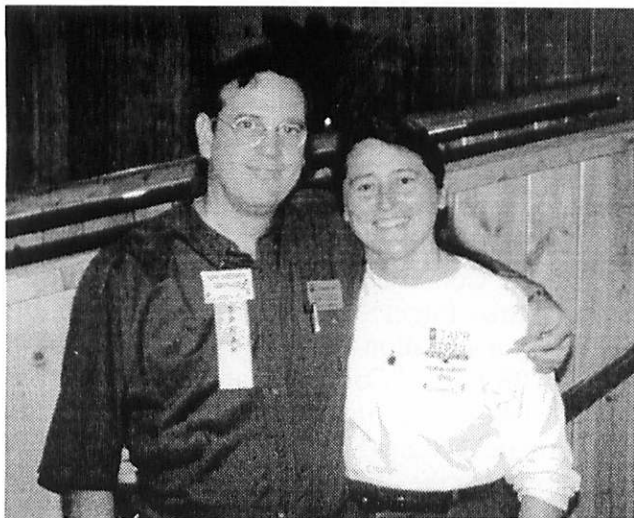

Lyle, WA7GXD, and Heather, N7DZU, Johnson.

development steps that had been done for the simulator. Johan then presented a talk on his current development of Quator. Quator is Johan's research in developing a new robust HF digital modem. The presented materials looked very promising and everyone looks forward to seeing further development. The final discussion focused on the future of HF-SIG.

### Sunday, September 22nd, 1996

The first workshop on Sunday was by Dewayne Hendricks, WA8DZP. Dewayne's workshop focused on the aspects of using Part 15 wireless devices and their potential usage in Amateur Radio. Dewayne provided a laundry list of devices on the market currently and the audience took a lot of notes and asked a lot of questions about the different units. Dewayne outlined the planned introduction of two SS radios by TAPR (one at 115Kbps and another 256Kbps) in coming months as part of the ongoing Spread Spectrum rule changes in Washington. This workshop allowed those in attendance to grasp the reality and ease of implementation of truly high-speed amateur radios in the near future.

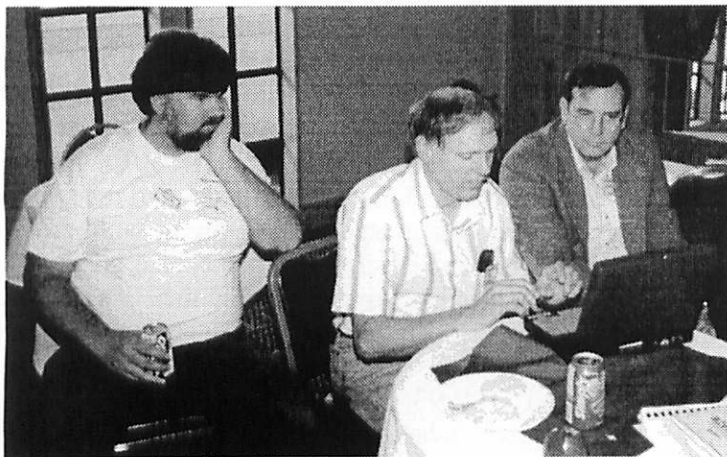

BDale Garbe, N3EUA, Glenn Elmore, N6GN, and Lyle Johnson, WA7GXD, sit in the hospitality area and discuss some of Glenn's new RF software.

The second workshop on Sunday saw Barry McLarnon, VE3JF, provide an overview of what 56K is all about, including a survey of available hardware, networking design, and some hints based on 56K experience in the Ottawa area. Dennis Rosenauer, VE7BPE, followed with an entertaining and informative slide show on the 56K system which has been set up in the Vancouver area. Gwyn Reedy, W1BEL, contributed an update on current and future 56K-related products from PacComm. An array of 56K hardware was

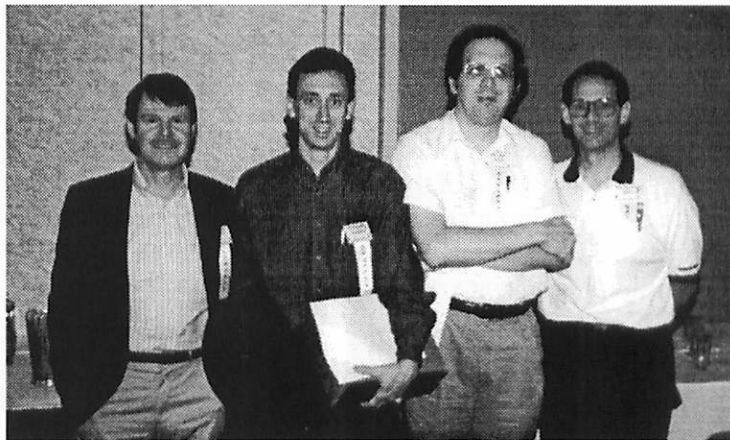

Johan Forrer, KC7WW (TAPR HF-SIG Chair), with Tim Bagget, AA5DF, Phil Kam, KA9Q, and Tom McDermott, N5EG, after the HF SIG meeting.

displayed and demonstrated, including two complete 56K stations based on PCs running Linux, provided by Dennis. The Linux boxes were networked to other PCs via SLIP and ethernet. Also on display were the new WA4DSY 56K modem, a Gracilis PackeTwin interface card, and the SPIRIT-2 PAD unit, all from PacComm, and an Ottawa PI2 card and Microwave Modules transverter from VE3JF. Everyone attending seemed to really enjoy the presentations and the ability to ask questions about the equipment at the end of the workshop.

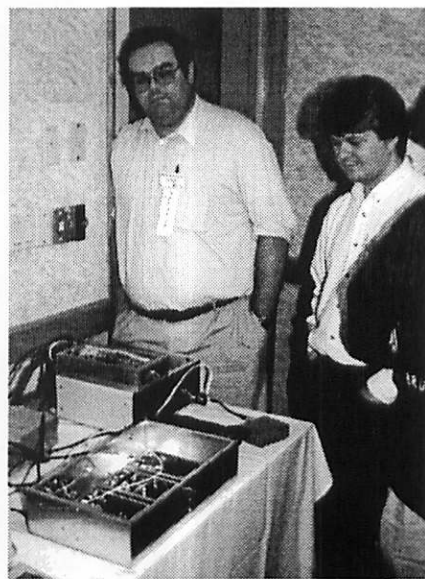

Dennis Rosenauer, VE7BPE, showing some of the 56K equipment being presented during the 56K workshop.

## Concluding Comments

The ARRL and TAPR Joint Conference Committee is now looking at sites for next year. The group has a proposal from NJ and MD to host next year's conference. There should be details as to next year's location by the first of 1997. Look for the ARRL and TAPR DCC on the East coast sometime the end of September! Until next year!

## Proceedings

Not everything published in the proceedings got presented at the conference. The following are the titles and authors for those papers that were not presented. The proceedings are now available from both ARRL and TAPR for \$12.00. Full abstracts are available on the TAPR web page ([www.tapr.org](http://www.tapr.org)). In addition, TAPR now has the complete set of proceedings available if you are missing any past issues.

Learning DSP by Porting Programs to the TAPR/AMSAT DSP-93 Modem by John Bandy, W0UT

Linking BPQ Switches via Ethernet by Bill Barnes, N3JIX

The Radio Amateur Digital System Artificial Intelligence Project by Garry W. Joerger, N5USG

Fast Flow Control in High-Speed Communications Networks by C.M. Kwan, R. Xu, and L. Haynes

Nonlinear Channel Equalization Using Fuzzy CMAC Neural Network by C.M. Kwan, R. Xu, L. Haynes, and J.D. Pryor

Optimization of Phase-Locked Loops with Guaranteed Stability by C.M. Kwan, H. Xu, C. Lin, and L. Haynes

Easy to Follow Packet by James Nobis

XNET: A Graphical Look at Packet Radio Networks by Richard Parry, W9IF

13cm PSK Transceiver for 1.2Mbit/s Packet Radio by Matjaz Vidmar, S53MV

23cm PSK packet-radio RTX for 1.2Mbit/s user access by Matjaz Vidmar, S53MV

The Word Storage Relay by Pat West, W7EA

On-Air Measurements of HF Data Throughput Results and Reflections by Ken Wickwire, KB1JY

On-air Measurements of MIL-STD-188-141A ALE Data Text Message Throughput Over Short Links by Ken Wickwire, KB1JY

The Technology Grows and Matures by Bill Henry, K9GWT

## Banquet Speech by Lyle Johnson, WA7GXD

From the ARRL and TAPR 1996 Digital Communications Conference  
Seattle Washington, September 21, 1996

Transcribed by Steve Stroh, N8GNJ

Audio and photos are available on <http://www.tapr.org>

Well, as you can probably tell, this is the first time I've ever done one of these, so I want to thank everybody for the opportunity to do this. I want to thank Greg Jones, WD5IVD, for inviting me. What I understand the ground rules on this are that: if this goes over OK, Greg gets the credit for his wisdom; if it doesn't, it's my fault. And besides that, I know you're really here for the prize drawing so I'll try and keep this short.

My personal involvement with TAPR (heavy involvement, that is) on the board and as an officer and so forth, ended about three or four years ago. I left at that time feeling it was really time for some new blood with a new organization, new directions of leadership. Four years ago when I left, I was very, very proud of TAPR and what it had accomplished. And today I can honestly say that I'm just as proud of what it's still doing and I want to thank Greg for doing an excellent job. (Applause)

We have a number of students with us this year. I understand with the first ever student awards that some of these students may not be terrifically familiar with Amateur Radio. So, I'm going to touch on a few things that may seem a little bit basic; for them it's new, for the rest of us it's a refresher.

One of the points I want to make is that we must keep in mind that Amateur Radio is a Service that we have under the FCC. We often talk about this wonderful hobby that we have, but hobbies are like tying fishing flies. This is a Service, it's licensed by the government, under government regulations.

And one of the things that strikes me about this is that the public has entrusted us with billions of dollars' worth of spectrum. Some of it's exclusive, some of it we share with other services. But, we're finding out more and more these days that the public is expecting its money's worth. And remember that the public that's granting us this privilege is the same public that brings lawsuits about our big antennas in our backyards.

So the Amateur Radio Service was formed in the Communications Act of 1934. There was a basis and purpose for it and there are four (if memory serves me correctly) basic pillars or precepts upon which our Service is formed. One of them would be public service, emergency communications, things of that nature. Another is to provide a trained reservoir of technicians

and operators in times of national emergency. A third is to advance the radio art, and the fourth is for international goodwill.

And the thought struck me the other day when I was wondering about what should I talk about to this group of people. I was wondering, "This is 1996, not 1934. Would the FCC establish the Amateur Service today, in today's climate?" If we weren't trying to preserve what we had, but trying to carve out something new, would they take spectrum from someone else and give it to us? And if they would do it today, would they do it ten years from now or fifteen years from now? I got to thinking about that a little bit. And in 1934, public service communications radios were fairly rare (in 1934) and Amateur Radio could step in and do quite a lot. In 1996 we still provide public service but I think the public is a little bit less dependent upon us now than they were in 1934. What about the year 2010?

In terms of providing technicians and operators, certainly in 1934 it was a wise choice. In 1940, 1941-42 we went to war and a lot of the same equipment that was in our ham shacks wound up on the front lines and the same people operating that same equipment. In 1992 with Desert Storm, I'm not sure how many hams were invaluable in Desert Storm. I'm not sure what would happen in 2010 if, God forbid, we had to fight another war.

In terms of international goodwill, in 1934, we've all seen the Indiana Jones flicks- everybody climbs on a Pan Am clipper, all eight passengers, and they fly for days to get across the Pacific ocean stopping for fuel at every passing boat. Today, travel is inexpensive; it costs pennies instead of dollars now. Everybody travels; it's ubiquitous. Last week at this time I was on my way to Brazil on business. I left on Saturday, I was in Brazil Sunday and Monday and part of Tuesday and I was back at my desk Wednesday afternoon before I came here Wednesday evening. Travel — it happens. We get international goodwill now by face-to-face meetings rather than necessarily by Amateur Radio.

And what about advancing the radio art? Certainly in 1934 we contributed a lot. In 1996, I think we're still contributing, but it's somewhat less. But I wonder about what might happen in 2010.

To touch some of these points again...

In terms of public service, I remember when my brother was stationed at government expense in a beautiful tropical paradise near the Cambodian border. And he was able to call home from time to time through something called MARS - the Military Affiliate Radio System, which was basically Ham Radio. And he called home and we got to talk to him for sixty seconds or one hundred and twenty seconds and then it was the next GI's turn. But in Desert Storm the phone company just put phone booths out in the desert and people just direct dialed home. MARS wasn't terribly relevant then.

Nowadays when a disaster hits, another hurricane hits the East Coast, a twister hits the Midwest, the infrastructure gets damaged. When that happens, the hams step in and they provide emergency communications. How long do they provide that for? Months? Years? No, until the technicians fix the commercial infrastructure, then the commercial services take over again. Why? Because they're more efficient.

So, what's going to happen in a couple of years when Iridium will be here, the little LEO satellites get launched, and now you can grab your cell phone and you can directly link with the satellite, and the infrastructure doesn't get damaged when a hurricane occurs. How meaningful are we going to be at that time? If you're driving down the road and you see an accident, you grab your two meter radio, you bring up the phone patch, but four other people have already driven by with their 900 MHz handhelds and they've already reported the accident by direct dialing 911. So I think that if we look today, and towards the future, that one of those pillars that has held Amateur Radio up, that of Public Service, is going to be providing diminishing returns to the public in terms of these billions of dollars of spectrum that they're authorizing us to use.

What about trained operators and technicians? This afternoon we were down there looking at this really neat Kenwood, what is it? A TS-870 radio with dual digital signal processors. How many people here can fix it? How many people here think Kenwood can fix them?

How many people have an HF radio with Automatic Link Establishment protocol built in that they use in Amateur communications? Not too many. (What I'm trying to point out is that there's a divergence between what we use and what the government or the military might use.) How many of you have set up a satellite ground station? How relevant is our experience to a real-time graphics display in an Abrams tank or a Bradley fighting vehicle that's rolling over a battlefield with all the enemy and all the good guy positions all illuminated on there for their fire control systems?

In Desert Storm, there were some thin route communications used on the front lines that were based in some degree on Amateur-developed technology in TNCs and so forth. We did make a contribution to Desert Storm, but it was in technology more than it was in people.

In terms of international goodwill, I think I already touched on the fact that travel nowadays is cheap and Americans go everywhere all the time. I'm not sure how much international goodwill is promoted when you turn on twenty meters on any weekend you want to pick and hear "CQ Contest" or "Hello Contest".

If you were the public — if you were the administrator — would you be willing to give up a billion dollars of public spectrum for what you hear on the HF bands in terms of international goodwill? I'm not saying what

we're doing is bad, I'm simply wondering, within the perspective of the billions of dollars that we're now faced with, what will we do?

So, to me, the pillar that's left, the strong one, is advancing the radio art. I think that's what we have to build our case upon. I don't think that we can build a strong case upon other things in the future, although we can to some degree today. Clearly, that's what the DCC is all about, that's what TAPR, AMSAT, AMRAD, and the ARRL is heavily involved in, that's what we do, that's what we're involved with — trying to advance the radio art. But to do the radio art, you need radio, right? You need spectrum. OK? So we can't waste the spectrum.

Now, a fellow at work a few weeks ago handed me a book that I read (I must have been terribly bored). The name of the book was "God Wants You To Be Rich" by Paul Pilzer. What does that have to do with radio spectrum? Well, this fellow that wrote this book had a strange view of economics. He didn't believe that economics was "handing out scarce resources," he felt there were abundant resources. And he made three points that kind of stuck with me.

One of them was, he gave an example of a ketchup factory in the Midwest. And this ketchup factory used to employ, I don't know, a gazillion people, now I'm sure they employ half a gazillion. But they didn't just make ketchup, they made the glass bottles, they made the labels, they printed them, they screwed the caps on them, they owned a fleet of trucks to distribute the ketchup around and they started being eaten alive by their competition during the 1980s. They shifted things a little bit and found a company that made plastic ketchup bottles cheaper than they could make glass ones. So they started buying plastic bottles. They found another company to make labels cheaper than they could make labels, and they found that they could contract with a trucking company cheaper than they could truck it themselves. In the end they wound up making more profit, selling more product, at a cheaper price, with a leaner organization because it became more efficient.

How is this related to what we're talking about?

Well, a lot of times I hear a real hue and cry when we talk about Amateur Networking, and "we've got a local area net over here in Tucson," or maybe "they've got their local area net in San Diego and this is Amateur Radio and we've got to tie these together by radio - we've GOT to use radio!" Well, people just sort of make sure nobody's looking and connect it up to the Internet, and BOOM - they create a wormhole and we get messages across. Well, what's going on here? Well, we're being more efficient - we're subcontracting out those services that can be more efficiently provided by others and focusing on the things that we can do well. I think there's some relevance there. We could raise up our hands and say "that's not Amateur Radio," but maybe it

doesn't have to be Amateur Radio to CONTRIBUTE to Amateur Radio.

Another point this fellow made was that nowadays we're creating wealth from absolutely nothing. Well, you say "What are you talking about, Lyle?" Well, there's a couple of things.

In the 1800s, there was a kind of a crisis that occurred because they realized that the Yankee Clipper Ships were going out there and taking out the whales faster than the whales could make more whales. And this was a problem because everybody lit their house (back in those days) with whale-oil lamps. And how were they going to have light for their children or grandchildren if we killed all the whales? So they decided that maybe we should cut back on the hunting a little bit, or this or that.

But, a couple of things happened in the meantime. There was this guy named Edison, and he got some bamboo filament, and this and that, and he made an electric light bulb. "Hmmm, this might have some applicability to saving the whales?" Another fellow went walking around, he was in Pennsylvania somewhere I guess, and noticed there was this perfectly good farmland that "Gosh, it's ruined! There's this slimy black stuff that's kind of oozing out of the ground here." Well, there's petroleum! Now, we don't want our houses lit with whale oil lamps. But tremendous wealth has been created with electric light bulbs, and with petroleum. Well, now we're running out of petroleum - but maybe technology will find another answer to this.

Twenty years ago there wasn't any viable PC industry in this country, but today the PC industry is roughly on par with the automotive industry in terms of its contribution to our economy. We're talking about an industry that did not exist twenty years ago!

And what is the PC industry, this tremendous wealth, what is this based on? Sand. Silicon - the most common element there is on our planet - silicon. But that's what a huge fraction of our economy is now based on, something that we walked out on and just shook it out of our shoes and walked down the beach and didn't worry about it much.

Well, what do we need? We need spectrum. How are we going to get that spectrum? Maybe we're going to get it by applying technology in ways that we haven't applied it before to create, in effect, more spectrum.

Another point this fellow made in his book was the accelerating pace of change. He pointed out that in the 1930s there were tens of millions of people that were involved in agriculture in this country. And each farmer could feed his family and two or three others. Now, in the 1990s, we have just a few million farmers, but each farmer can feed his family and about a hundred others. Farmers are far more efficient.

Well, that's great for those that are still farmers, but what about those tens of millions that aren't farmers anymore - what did they do? Well, over a period of a few decades, as this revolution was occurring, they moved to the cities. And what did they do? Well, some of them went to factories in the automotive industry and built carburetors. And others went to the recording industry and built vinyl LPs.

And then what happened in the 1980s? We went from employing a million or so people making carburetors in this country to nobody making carburetors. Why? Because we're using electronic fuel injection. And what about the people making vinyl LPs? In 1983 they had a job. In 1985 they didn't. Why? Because of the Compact Disc.

We're going through changes where, in the past, it took a generation or so for a major change to occur; to where my children are going to probably face two or three major changes in their career growth during their normal working lifetime. Something we've never had to deal with because of the incredible accelerating rate of the advancement of technology.

In the 1950s and 1960s when I went to school, nobody ever heard of the PC, we didn't care much about sand, what was good for GM was good for the nation. We had slide rules, log tables, and ham radio. My kids went to school in the 1980s and 1990s and what did they use in school? Graphing calculators, and they hook up to the World Wide Web. They take their tests electronically at home, they do their homework electronically and e-mail it in to their teacher. What's going to happen with my grandkids? I don't know either.

In the 1970s, or up to the 1970s the U.S. economy was based on manufacturing. Today, our economy is based on information and services. As Greg pointed out in his latest PSR editorial, it's a paradigm shift - looking at things completely differently. It's like "Dead Poet's Society" where everybody stands on the desk and looks around. It's a different perspective on life. We worry about the loss of manufacturing. Well, gosh! Japan made six billion dollar's worth of VCRs last year. Yeah, but Hollywood made SIXTY billion worth of movies for those six billion dollar's worth of VCRs.

Well, let's shift gears a little bit and gaze at the digital Amateur station of ten years ago. It's 1986 - most of us can still remember back that far. You had an 8088 or 80286. 1986 - OK, maybe you had a Mac as well. You had a megabyte of DRAM, you had a forty megabyte hard drive, you had an EGA monitor (how many remember EGA monitors?). You had a Z80 TNC with a 1200 baud modem plugged into the audio jacks of your two meter radio, and you had a 1200, or if you were rich, a 2400 bit per second connection to The Source, or maybe CompuServe.

Let's look at that same digital Amateur station today. It's now 1996. You've got a high speed 486 or Pentium, it's got

at least eight megabytes of RAM, you've got a one gigabyte hard drive and a SuperVGA monitor. You've got a 28.8 kilobit modem that cost \$99 connected up to your \$20 per month Internet connection. And you've got a Z80 TNC running at 1200 bits per second connected to your two meter radio. (Laughter)

What's wrong with this picture?

Advancing the radio art is how we're going to retain what we have. Let's look at something else. Pretend it's 1944 now (I think most of us will have to pretend). If you ran into QRM on the frequency, well, what would you do? You'd QSY, change frequency, you'd QRZ, be sure the frequency was clear, and then you'd call CQ. What do we call that? Frequency Division Multiplexing. We got a problem, we change frequency. In 1954, you know, 10 years later, Single Sideband was starting to come on past the Dan Norgaards and so forth and was up to the Wes Schuns and the Central Electronics guys. And you had Single Sideband, you cut your spectrum in half so you could put twice as many people in the same amount of spectrum. It was still FDM, right? In 1996, we're using what? Single Sideband. Same as we were using in 1954. It's nearly fifty years later. We're still using the SAME techniques.

In the 1970s, FM repeaters suddenly took over the landscape in Ham Radio when it went from basically zero in 1970 to five thousand today (and I imagine that eight years ago it was four thousand, nine hundred and fifty). What happens today in 1996? You go to Ralph, your local frequency coordinator, and say "Ralph, I need a frequency for my repeater" and Ralph just kind of says, "What else is new?" Right? There aren't any.

So Ralph, your local frequency coordinator, he's empowered as a kind of a God now. He can hand out these frequencies — these frequencies that are worth millions and millions of dollars. Ralph controls them now. And Joe Ham, who's a repeater owner, carefully warehouses that spectrum. He doesn't use it much but he wants to be sure nobody else can use it either, so he has his frequency coordination thing. Meanwhile he goes to another channel that Ralph gave him so he can run his remote base on the mountaintop so he can call CQ DX. And that's cool, that's good.

But somebody else went up to a local mountaintop with a spectrum analyzer one day and they scanned two meters. And they noticed that "I can't get a repeater allocation. Yet, if I scan this band and make a graph over twenty-four hours, I'll find that this band is maybe being used five percent." Maybe in our area it's being used twenty percent, but I doubt it.

There's something wrong here. So we're very busy organizing things so we can warehouse spectrum with closed repeaters that other people can't use. There's something wrong here I think. Does this sound like a good

idea to you? That we promote this, we organize ourselves around this, and we defend this?

Now if you were a public policy maker, how would you feel about this? How would you react to the creation of this kind of a Service? Neither would I.

Well, now we've got this what we call the Little LEO controversy — the low earth orbiting guys. And they sat up there with their spectrum analyzer and noticed the same thing. So, now they've gone to the policy makers, and amongst the candidate bands (and we've all read the "QST" editorials) there's two meters and seventy centimeters on the table for consideration. Not to be taken, but to be shared. And we're treating this, and I suppose properly, as a call to battle — we have to battle those little LEO guys. "We can't possibly let them share our spectrum - this is our sacred stuff." Joe's gotta have his warehouse because Ralph gave it to him, right?

I don't look at this so much as a call to arms, I think it's a wakeup call.

I think that if we look at ourselves objectively, we have to say that we're grossly inefficient and that we're wasteful. We've been given a precious public resource and we're not utilizing it properly. Now the Little LEO guy can put his Spread Spectrum satellite on top of two meters and claim that he's not going to interfere with us, and he'll accept whatever we can dish at him because he knows how to handle it. Well, it's hard to argue that we're not going to share this underutilized resource with you because Ralph said it belonged to Joe... And I believe that this coexistence has been demonstrated to some extent with the STAs that were mentioned earlier in the Spread Spectrum talks today.

Well, it seems to me we have a choice here. We can either share our frequencies with the Little LEO guys, or we can share it with ourselves. If we don't share it with ourselves, we're going to have to share it with somebody else that might not be of our own choosing. So, it seems to me that we need to push, really, really hard. And TAPR is doing this, and the League is doing this, we need to push really hard to get the Spread Spectrum rules relaxed.

How relaxed?

My feeling of how Part 97 should read is easy — "Here's your band limits. Have a nice day." I think we could fit the whole of Part 97 on this side of this three by five card in large type. So that even a bifocal guy like me could read it without glasses.

Well, let's go back to the little Z80 TNC that I talked about.

If you look in your Proceedings that you received today, and I think everyone here got one, you'll notice on page 145, and again on page 177, there are articles in there

for an L band and an S band digital transceiver. Runs at 1.2 Megabits per second. It's pretty slick. These were designed by Matjaz Vidmar. Now Matjaz is a sort of down-the-totem-pole level professor. Whatever an entry-level professor in Slovenia (I don't speak Slovenian, I'm not sure if anybody here does) is called. He did this at the University of Slovenia. Can anybody locate Slovenia quickly on a globe? (There are a few that can. Alright, that's good. Most people, if you said Slovenia, they wouldn't know where it is.) Now, this is not a wealthy guy with a cadre of highly-paid highly technical people under him, and the economic powerhouse with highly technological infrastructure of Slovenia that dominates Europe today. This is a guy that's working in his house, making circuit boards, drawing pictures, using X-acto knives. But in a smaller European country, he is sharing with us this development that he has of a 1.2 Megabit radio. I remember, several years ago, we tried to make a 9600 bit per second radio, and we just sort of never did that.

So, granted, Matjaz is a very bright guy. But there are a lot of other bright people around here. What I'd like to see is TAPR, just as we revolutionized things with 1200 baud many, many, MANY years ago, or helped contribute to that, I'd like to see us revolutionize things at a Megabit. And I think we can do it — the plans are right there, they're right in the book — that can cost a couple of hundred dollars to build. I held it in my hand last October when I was in Germany. I met with Matjaz as we were working on the Phase IIID project. Incidentally, that design that he has there is the basis of the 153.6 kilobit PSK modem that's going to be riding onboard RUDAK in Phase IIID, that's going to have Phil's convolutional encoder on it.

So, I think the stuff isn't magic, certainly. I think that, in my opinion, the only surviving basis that we're going to have over the next years for retaining our spectrum is technological advancement. I think we need to keep pressing on. I think we need to be very aggressive. I think with the rate of change and pace of change we need to be less conservative and more assertive. I think we need to expand our participation, speaking from a TAPR viewpoint, in the FCC and ARRL processes, and I know that TAPR is doing that. I think we have to press HARD for Spread Spectrum. We need to develop radios, we need to put them in people's hands just like we did with the Beta Test in 1982 with TNCs. I'd love to see a Beta Test in 1997 of Spread Spectrum radios to get out there into the Amateur community. I'd like to see us pushing the bit rates faster and faster.

Above all, I want to see us have a lot of fun. Because this is an Amateur Service - we're not allowed to make money at it so we might as well have a good time.

Thank you very much.

## One person's view of DCC '96

Steve Stroh, N8GNJ  
strohs@halcyon.com  
n8gnj@sw.n8gnj.ampr.org

It's rare that one gets to personally participate in a paradigm shift as it happens, or even to be aware that a paradigm shift is underway. Yet, that was the situation I found myself in at the 15th ARRL and TAPR Digital Communications Conference (DCC) that was held September 20-22, 1996 in Seattle, Washington. I think the 1996 DCC will be viewed in retrospect as a milestone in Amateur Radio. To me, it is an absolute certainty that if Amateur Radio is to have a future, it will be based on Spread Spectrum techniques.

### A Short Spread Spectrum Tutorial

The unofficial theme of DCC '96 Seattle was Spread Spectrum (SS). To grasp the paradigm shift, you have to have a basic understanding of SS - very basic, fortunately, so the following is a brief tutorial on SS. The Frequency Hopping technique is easiest to describe. The "other" SS technique is Direct Sequence Spreading (DSS).

Like many hams, I'd heard the words and had a vague idea that they involved "spreading out" an RF signal across a range of frequencies, and this "spreading out" made the signal less prone to interference, and therefore able to share that same range of frequencies better than existing narrowband techniques. But I didn't have any idea of HOW SS worked. In the Frequency Hopping method, a "channel" is occupied briefly while transmitting, then the transmission is "hopped" to a different frequency, and then to another, and another, etc. The "magic" of the Frequency Hopping method, as I understand it, is the particular "Hopping Sequence" (HS) that is used to determine where the "hopping" occurs, and when. If two or more transceivers use the same HS, they can communicate. If they don't use the same HS, they aren't even aware of each other. Yes, occasionally there are "collisions," but those are easily dealt with by using Forward Error Correction (FEC) techniques that encode redundancy into the data such that a collision can be detected and corrected without a retransmission of the data.

The analogy that I use to think about SS, and explain it to non-hams, is that the conventional approach is like each business, school, church, government office, etc. each constructing their own private network of roads. The SS approach is how roads actually operate - roads (a range of frequencies) are available for everyone for shared use. As long as two or more individual vehicles (transmissions) don't occupy the exact same spot at the exact same time (the Hopping Sequence), no problem. If it did become a problem, all the vehicles would get a little

more careful (a better Hopping Sequence) or a little better "armored" - like driving a Volvo (better Forward Error Correction).

The combined effects of SS, FEC, data compression, link layer protocols, and the use of low and variable transmit power adds up to pretty fast data rates - 100 CPS is slow for typical SS modems in the 902-928 MHz band. This is fast enough to do good digital voice, and fast enough to begin thinking about digital video (consider that Intel is pushing the use of Pentium 166s as being good enough to do videoconferencing over conventional analog phone lines, using 28.8 Kbps at best data rates.)

The "mindset" of SS is a profound change from business as usual in Amateur Radio (and many other radio services). With SS, you don't need frequency coordination in the usual sense - choose a HS, say A23 (fictitious example), and an appropriate range of frequencies (420-450 MHz). As long as no one else chooses HS A23, you aren't even aware that anyone else is using the same set of frequencies. Another group, actually MANY groups, want to use 420-450 MHz. They choose other hopping sequences - B72, or C17, etc. They aren't any more aware of other groups of users than you are with your original use of A23. The "tuner" in your SS radio is actually choosing a Hopping Sequence. "Everyone" is using "all" the frequencies, so there's little need to coordinate the use of frequencies.

Stay with me in the tutorial for a bit longer. Remember previously that using the frequency hopping method of SS that "collisions" will happen, and can be dealt with through the use of FEC. A conventional analog transmission in the same frequency range can be considered a collision, and handled accordingly. Conversely, a SS transmission shouldn't bother the analog transmission because SS is commonly implemented at low power levels - a 1W SS transmission in 420-450 MHz is unlikely to interfere with a typical 25W analog transmission. The combination of the hopping sequence and error correction will determine how robust the signal is. Effective hopping sequences are a "fertile area for future development" - meaning much work is to be done. Commercial SS implementations are "robust" enough to provide good data rates in congested frequencies. Consider that 902-928 is considered a "garbage dump" band - wireless stereo speakers, wireless TV links, cordless phones, and wireless data all coexist effectively there. Coexist so well, in fact, that one company, Metricom, is using 902-928 MHz to implement a wireless Internet access service targeted at consumers. Commercial vendors have developed SS techniques that work pretty well. Amateurs can certainly develop SS techniques that work even better. The need for much more SS experimentation by Amateurs in the Amateur bands is why TAPR has requested a Special Temporary Authority



(STA) to use SS techniques in Amateur bands above 50 MHz. End of tutorial, now back to DCC '96 Seattle.

I should take this opportunity to point out that DCC '96 Seattle wasn't exclusively about SS. These are personal impressions, and what I was most interested in and focused on was spread spectrum I also had periodic host duties to perform and wasn't able to attend as many presentations as I would have liked. There were many other fine presentations at the DCC about non-SS topics. This article's focus on SS shouldn't detract from these other presentations. That said... I do think that DCC '96 Seattle will be remembered primarily as "The SS DCC," and a key point in the paradigm shift to SS in Amateur Radio.

I feel that it was very significant that this was the first DCC attended by ARRL President, Rod Stafford, KB6ZV, (or, I'm told, any ARRL President), and that Rod attended many of the SS-related presentations.

Paul Rinaldo, W4RI, presented his paper on Amateur Radio Digital Voice Communications. Paul stated that Amateur Radio really needs to have a Digital Voice (DV) technology. It seems that the fact that Amateurs aren't using DV technology is seen as detrimental in the eyes of the FCC. As Paul was talking, I was thinking of a TNC-2 with a 9600 baud modem, with microphone and speaker jacks on the back. The mic and speaker would be connected to a small daughterboard that contained one of the current generation of 90 second or so digital voice storage chips. When the Push To Talk switch is pressed on the mic, the mic audio is digitized and stored. When the PTT is released, the stored digitized voice is transmitted over the packet link, and transferred into a like chip in another TNC. When the transfer was complete, the transferred, digitized audio was played back on the remote TNC. I also thought of a demonstration I saw a few years ago at Dayton where Gracilis demonstrated a simple digital audio technology that used SoundBlaster boards. Tap the space bar on a PC with a SB, talk into the microphone, and tap the space bar again. Your voice is digitized and transmitted over packet, and played back through the SB in the other computer. After attending SS-related presentations later in the day, I thought back to Paul's talk and realized that SS techniques could EASILY provide a digital voice capability. It seemed to me that there would be so much bandwidth available in a SS system that voice could simply be interleaved with data. Enough bandwidth that voice digitization techniques didn't have to be particularly efficient, and such techniques already exist. I also thought of the many "Voice over Internet" techniques that are being developed and used. Hams already know how to do TCP/IP well.

Steve Bible, N7HPR, gave an EXCELLENT talk on "Introduction to Spread Spectrum." My above tutorial on SS comes largely from what I learned at Steve's presentation. Unfortunately, none of the "Intro Track" topics at the DCC were printed in the DCC proceedings, nor were handouts available (as was the case in the workshops). Steve did an excellent job in distilling much SS information into an understandable presentation that allows an average Amateur to understand WHY SS is such a paradigm shift for Amateur Radio and why it has so much promise. That Steve's presentation wasn't available for distribution was one of my few criticisms of the DCC.

Glenn Elmore's, N6GN, Introduction to High-Speed Networking was memorable for illustrating how much improvement in a communication system can be gained by reasonable attention to the physical layer. Not only is system gain a factor (avoiding loss of signal in coax, beam antennas instead of omnidirectional) but clear paths are vital also. Horizontal polarization can often work better than vertical, and circular polarization can be used in terrestrial as well as satellite communications. Probably Glenn's most important point was that low power not only is possible, but desirable. Interference that isn't generated (RF sprayed where it's intended, and not sprayed where it's not, doesn't have to be filtered out). This enables frequency reuse. Another key point was that if Point A and Point B don't have line of sight paths, but they both do have line of sight paths to a common (usually higher) point, put a relay system of some kind at the common point.

Phil Karn, KA9Q, talked about Progress on Coding (or why my DSP-93 is still sitting on the shelf). Intel's current Pentium microprocessor family has more than adequate (with careful coding) computing horsepower for Amateur communications. The higher clock speed Pentium and Pentium Pro improve the situation even more. A basic Pentium PC has amazing bang for the buck. Phil has been working on Forward Error Correction schemes. Phil tried to educate the crowd that FEC is not just a means to recover from errors, but actually can have the same effect as adding RF gain to the system (the FEC "gain" is no different in effect from "real" RF gain). How this works is that you can use lower power and still recover the signal - the signal can afford more fades and other "noise". The use of lower power is a net gain for the system since frequencies can be reused, and if other systems aren't using high power and interfering with others, the system works that much better. FEC is an integral part of effective SS systems.

Lyle Johnson, WA7GXD, was the featured Banquet speaker on Saturday evening. Lyle's talk, for me, was the high point of the conference. Lyle's talk brought together WHY Spread Spectrum is so vital to Amateur Radio, and

pointed out the absurdities of hams denying other hams the ability to experiment with new modes on Amateur frequencies. Lyle's talk was recorded and a transcription is printed elsewhere in this issue and on the TAPR web page. Lyle's theme was "If the FCC Had Not Created the Amateur Radio Service in 1934, Would It Do So In 1996?", to which I would apply the subtitle "Would We Be Found Worthy Of Allocating Scarce Spectrum To?" I highly recommend reading the transcript or listening to Lyle's speech. (Disclaimer - I transcribed the speech, so I got pretty familiar with it. As dispassionately as I can, I still think it's a profound speech.)

On Sunday morning, Dewayne Hendricks WA8DZP gave attendees a reason to be up when he presented a Workshop on "How To Utilize Part 15 Radios For Ham Applications." Dewayne has been doing extensive testing of Part 15 Wireless Modems as part of a National Science Foundation grant to evaluate the use of Part 15 Wireless Modems in connecting schools to the Internet. Dewayne gave a very thorough overview of the current regulatory climate in Washington and the FCC as it relates to Amateur Radio. The current situation is very different than what most of us might suppose, or even can imagine. Dewayne really electrified the audience when he started detailing just how good some of these Part 15 SS radios are. One of the most interesting units Dewayne discussed is made by FreeWave Technologies of Boulder, CO. The FreeWave units are capable of data rates of 115 Kbps (and that's conservative - throttled back from an over-the-air data rate that's higher) and ranges up to twenty miles... on one watt. Dewayne also described the "Part 5" regulations that are available to Amateur Radio (and other) experimenters. Part 5 allows great flexibility in choice of frequencies and operating modes, as long as there is no interference to the primary occupant of the band. The length of a Part 5 license is limited, but it can be renewed. Dewayne also discussed the Metricom Ricochet wireless Internet access network in detail. This was of particular interest to the locals attending the DCC because Metricom had just deployed a Ricochet network in the Seattle area. Metricom did a LOT of things right - low power, effective use of Spread Spectrum, a routing protocol that works, along with many other techniques that make for an effective system. Dewayne has had extensive experience with the first widespread deployment of Ricochet in the San Francisco Bay area. Dewayne has had both Ricochet and FreeWave units (and an NCR/Lucent Technologies WaveLAN unit also on 902-928 MHz) operating in close proximity with no apparent interference to each other.

On Sunday afternoon, Barry McLarnon, VE3JF, with assistance from Dennis Rosenauer, VE7BPE, presented a workshop on wireless networking using the WA4DSY 56K RF modem technology. Barry put together an excellent workshop handout (which was worth the

workshop fee all by itself), which I hope TAPR makes available on an ongoing basis. The theme of the workshop was that "56K" is now pretty much "plug and play." 56K has suffered from a lack of critical mass in several respects. Some of the equipment can be difficult to obtain, especially transverters. 56K requires a 100 KHz band segment, which is difficult to obtain in urban areas or North of Line A. Most troubling was that there wasn't a sense of urgency with most hams - WHY do you need digital communications that are that fast? That question has been answered once and for all with the exploding popularity of the Internet.

Equipment for 56K is easy now. WA4DSY has released a second generation of his 56K RF modem, and PacComm will sell it assembled and tested. The new modem is considerably simpler and easier to use. Another improvement in 56K is that dB Microwave, Inc., of which VE7BPE is a partner, is now offering a 28 MHz to 144 MHz, 220 MHz, and 440 MHz synthesized transverters specifically designed for the wide bandwidth requirements of the WA4DSY 56K modem. Yet another factor is that in the US, the ARRL has worked with the FCC to allow limited Amateur Radio activity in the 219-220 band, and that band has been divided into 100 KHz segments specifically intended for 56K use. The REAL driver of 56K is the ability to connect with the Internet wirelessly. Both the Ottawa, ON group (Barry) and the Vancouver, BC group (Dennis) maintain excellent links to the Internet. Initially, fast web page access is a goal. 56K and TCP/IP are a natural combination; TCP/IP really shines when coupled with a fast channel. In fact, the Vancouver group has found it necessary to obtain IP address assignments outside of the 44.x.x.x address space because the 44.x.x.x router (mirrorshades) simply doesn't have the throughput necessary to keep up with a 56K system.

Because of the excellent throughput of the 56K modem, activities such as digital video and audio are not only possible, but practical. Repeaters are the preferred method of constructing a 56K system in an area. There are a number of techniques which can make a repeater system less painful than it might otherwise be. For one, the 56K system can be cross-banded, input on 222 MHz and output on 440 MHz, for example. A simplified user station might be 2m 1200 baud transmitter, and a 440 MHz 56K receiver. The user can still get excellent download speeds such as web pages, since ACK packets are short and simple. As the user grows more sophisticated, he can upgrade to a more complex 56K transmit and receive station. The crowd was amused by VE7BPE's tale of tribulations building a custom UHF duplexer for a 100 KHz signal. The cavities were custom machined, and the tuning points were drilled and tapped by hand. The finished system works very well and is an in-band UHF repeater using a single antenna system.

During the conference, the upcoming Phase 3D satellite was frequently mentioned. Apparently the digital payload on Phase 3D will have some world class technology, enough to attract the interest of several of the attendees who were otherwise only slightly interested.

David and Mari Pedersen gave a very interesting slide show Saturday evening on their experiences in Africa. Dave and Mari work for Mission Aviation Fellowship to provide installation, training, and support for an e-mail network for missionaries working in Zaire. They use amateur HF Pactor and other systems to forward e-mail all over Zaire. E-mail is just another way to communicate in developed countries, but it was an absolute lifeline in countries like Zaire. There are practically no phones, satellite links are absurdly priced or outright prohibited, and the distances involved ruled out VHF and UHF except for very local communications. Because of the political climate, the ongoing revolution in telecommunications simply isn't expected to make much of an impact in countries such as Zaire. That Dave and Mari are able to do as much as they do is amazing.

Craig McCartney, WA8DRZ, presented his paper on "Constructing a Worldwide HF Data Network." Craig's company, Globe Wireless, was able to use a slightly modified Clover mode (occupied bandwidth was reduced from 500 Hz to 400 Hz) as the technological basis for a 24 hour a day automatic e-mail and file transfer system that uses standard marine HF transceivers. Not only is this system being used for e-mail transfers, but regular automatic position reports, engine telemetry, and software updates, pretty much irregardless of where you are in the world. I briefly daydreamed about sitting in some exotic port of call with a laptop answering e-mail, connected to my HF communication system on my sailboat via VHF and packet TNCs.

The Pedersens' talk, and Craig's presentation were interesting, but not just for the usual admiration of a clever implementation of technology. Both had implemented Amateur Radio technology, technology developed by folks experimenting on Amateur Radio frequencies, to accomplish real-life tasks that probably couldn't have been done in another way, and had a noticeable positive impact on people's lives. A key point of Lyle's banquet speech was that of the four pillars of Amateur Radio: public service, international goodwill, development of technical proficiency, and advancement of the radio art, only advancement of the radio art is likely to continue to be relevant in the late 1990s and beyond. The Pedersens' HF e-mail network, and Globe Wireless' global HF e-mail network are at least some proof that Amateur Radio can still be a fertile breeding ground for technological advancement... if there is room for experimentation to occur.

Playing host to a DCC is a special experience. In the weeks preceding the event, you begin to question your sanity that you're doing this sort of thing for anything less than very high pay. And all of the sudden it's SHOWTIME. People are forgiving of the occasional mix-ups. The attendance was a good mix from the local area and from around the country. Greg Jones' experiments with a live RealAudio broadcast of the paper presentations was a success, so much so that when the RealAudio feed went off-line temporarily, helpful listeners called the conference hotel to let us know (try explaining what RealAudio is to the average hotel desk clerk!). In truth, the local sponsor does very little except scout for a good place to hold the conference and recruit some volunteers for the event. Dorothy and Greg handled the "tough stuff" of handling registrations and negotiations with the hotel. Hospitality can be a determining factor in how welcome attendees feel. Fortunately I was blessed with my wonderful wife, Tina, who very much enjoys hosting events. Tina commented to me that "she doesn't mind me hanging around with THIS crowd of folks, they're REALLY nice and REALLY, REALLY smart." (I can only assume that this was meant to contrast with my "usual" crowd of Amateur Radio pals, you know, the guys who do TCP/IP, Linux, fast wireless data, and other weird stuff.

Long after the hot topics at an individual conference have faded into irrelevancy, it will be the face to face contacts that will have mattered the most. Meeting someone like Glenn Elmore, N6GN, whose work you've admired for years; picking up a conversation with Bdale Garbee, N3EUA, that was left off at last year's TAPR Annual Meeting in St. Louis; finally GETTING IT (a hint of understanding about how Spread Spectrum works) in an Introduction to Spread Spectrum session by Steve Bible, N7HPR; being around Phil Karn, KA9Q, who invented Amateur Radio TCP/IP (with a lot of help); and most of all, being humbled to watch how much of herself Dorothy Jones, TAPR Office Manager, puts into the ongoing work of renewing memberships, selling merchandise and kits, and just generally letting people see the all-too-humans behind the TAPR logo. I need to make a special mention of Greg Jones, WD5IVD. Greg is a dynamo; he makes you humble just watching him in action. That TAPR has accomplished what it has, and will accomplish great things in the coming years, is entirely due to the efforts of its unpaid officers and many, many volunteers. If you want to be involved in something great in Amateur Radio, you can't do better than to get seriously involved with TAPR.

---

## HF-SIG and the DCC

Johan Forrer  
forrerj@peak.org

Here are my impressions of the ARRL/TAPR Digital Communications Conference (DCC) held in Seattle, September 20-22, 1996.

First, let me thank the hosts: BEARS (Boeing Employees Amateur Radio Society) for all the kind and generous hospitality. The conference venue was excellent, food great, and we were kept entertained and happy.

I also wish to thank ARRL and the folks from TAPR for all the hard work that have gone into making such an event successful. Just to illustrate; the proceedings consists of some 256 double-sided pages with excellent technical content, for example, two outstanding contributions on 1.2 Mbit/s digital transceivers by Matjaz Vidmar, S53MV - complete with schematics.

Like most of us, there was only opportunity to attend a few of the activities as much of it was in parallel sessions. Also, I did not attend any of the workshops, which were about APRS and high speed networking. My apologies that I probably won't do justice to the work and effort that went into doing these workshops. I heard it was great.

There was the usual series of introductory talks: Digital Communications, HF Digital Communications, and an Introduction to Spread Spectrum (SS). Greg Jones was a very energetic speaker and did a great job on the introductory stuff. Steve Bible gave a thought-provoking introduction to the topic of SS. What was interesting to me was hearing how such a new mode of operation would be like; some form of channelized tuning or scanning operation probably with a very strange-sounding background - like tuning the band but now it was all SS codes. It was evident that SS was on everyone's mind. The room was absolutely packed while the talk next door was only partially filled up - even though that also was a good one.

There were two papers by students participating in the "Best Student's Paper" - that went over well. The quality of their work was excellent. One presentation dealt with the control system for an amateur radio satellite ground station. Talk about sophistication! This one uses the QNX real time operating system (it is small and compact enough that it lives entirely in a Pentium's L cache) and he designed the various control modules using the object-oriented programming concept called "Actor(s)". I hope that the idea of the

Student Awards continues to attract such talented participants.

Phil Karn presented some of his recent work on concatenated codes. These are combined convolutional and block codes that have some rather neat properties. This talk was outstanding as Phil really is the master of this topic and the content was appreciated by many — judged by the full house. There was an interesting comment on the future of research on coding theory. Phil was talking here about "Turbo codes" and noted that once this has been formalized, the last bit of coding gain would have been accounted for. So if you were a coding theory theoretician, you had better find another field to work in! However, I suspect there remains a great deal of this fascinating theory to be explored in HF digital applications.

Interest in the future development of HF digital was shown in Craig McCartney's (WA8DRZ) talk, which was about a commercial marine radio operation - how HF digital communications and the Internet makes this possible.

The dinner speaker was Lyle Johnson — one of the founding fathers of TAPR. Lyle reminded us that the role and place of Amateur Radio in today's society was never as much in peril as it is now. Just think of the fact that we are still using 1200 baud packet and that SSB is still the main voice modulation method of choice. How long ago were these technologies developed? Why have we not made progress? It comes to no surprise that the amateur commitment to provide emergency readiness is being challenged by the Internet, robust fiber optic communications, LEO's etc. I hope the gloomy picture will inspire future experimentation and development of our spectrum resources realizing that there are eager eyes wanting to claim it.

The HF-SIG meeting was held after dinner and provided intellectual entertainment for those interested in HF. I think this was successful — at least from where I was standing on the other side of the podium! The topic this time was woven around past discussions we have had on HF-SIG regarding HF Channel simulation: Tom McDermott did an excellent presentation of the mechanics involved in simulation using the Watterson model. I followed him showing a number of "doppler grams", courtesy of Peter Martinez, G3PLX. These are really unique and worth seeing. A brief overview of software for the DSP-93 and a demo running this implementation of the Watterson ionospheric model, concluded this part of the meeting. I also presented an outline of the work that I have been doing on QUATOR.

I wanted to talk about the future of HF-SIG and made a desperate plea for someone to offer to help out. My personal business commitments have gotten extremely demanding, to the point where I just felt it necessary to step back and let someone else continue with the good work that has been started, and still continues, on this SIG. Being in the chair position means being at a focal point with a lot happening behind the scenes. One needs to process, cultivate, follow up, and be involved constantly as there are numerous exciting and worthy opportunities coming your way.

So keep that in mind: Anyone interested in helping run HF-SIG please get in touch with Greg or me. Otherwise as of the DCC, I will remain an interested party, but probably will stay on the sidelines and participate whenever there is an opportunity.

I trust that this summary is of interest - remember that these are my personal views and observations; one person's view of the world - I hope I have most of the facts straight but my short memory often let's me down. Thank you much to all that made attending the conference a worthwhile experience. It was great seeing all and I look forward to the next DCC (which I hear will be out on the East Coast).

---

## **New Viterbi Decoder Release**

Phil Karn, KA9Q  
karn@unix.ka9q.ampr.org

Hi. For anyone interested I have released a new version 2.0 of my Viterbi decoder routines. This release is substantially faster (50%) than my previous version (1.1). The gains came mainly from a change in the way that final decisions are made on the decoded data bits (I switched from the "register exchange" method to the "traceback" method) and also from continued groveling over the code. Thanks to the longer path memories that are practical with the traceback scheme, BER performance is also slightly improved, though the difference is probably significant only when decoding a high rate punctured code.

The decoding speed on a 133 MHz Pentium is about 259 kilobits/sec for the NASA standard rate 1/2 K=7 convolutional code.

Two versions of the decoder are provided. The first operates on finite-size 'tailed' packets as before. The second is written as a UNIX filter and can operate on a continuous stream of data, closely emulating a hardware Viterbi decoder.

I've updated my ham radio web page with pointers to the new distributions:

<http://www.qualcomm.com/people/pkarn/ham.html>

---

## **Florida Packet Group**

Richard Garcia, N2CZF n2czf@magg.net  
<http://www.magg.net/~n2czf/aprs.html>

Based on a highly heated debate on APRS-FL, started by yours truly, for the possibility of a Florida Users Group and 24+ attendees at the Melbourne Hamfest APRS Forum, a charter was written on September 15th to form the Florida APRS Users Group. Due to the vast territory we cover (The whole State of Florida) and that we have decided to form as a "Not for Profit group" there are many problems we will need to solve, one of them is money. It costs money to Incorporate and become NFP and we do not wish this group to become "formal" and require dues so this is our main objective to figure out now.

Since TAPR has given us the ability to have the APRS-FL mailing list we have floated at about 70-80 members that are signed up. This has been a WONDERFUL opportunity for us to stay in touch and help our fellow neighbors out! More than several APRS users in the state have signed up on Juno.com just to be on the mailing list and our networking ability has grown tremendously in the past 2 months. APRS users in areas that have little or no APRS activity can now find a helping hand as close as their modem, and can also work closely with others to establish APRS digis that can extend the range of the Florida network into their own local area.

New WIDE digipeaters have been recently set up in Jupiter, Melbourne, Jacksonville, and Ocala. At this time the Jupiter site is working on establishing a 100% path to Melbourne, the next Northern Digi, and possibly Grand Bahama Island in the future. We are also working with the Jacksonville group to get a link established to the brand new Ocala digi and possibly Gainesville very soon. Due to the range that we are trying to cover and our flat terrain here, this is no easy task since none of us are within easy reach. New sites are needed in the Daytona area and somewhere between Jupiter and Melbourne to make the system work well. If anyone in Florida is interested in APRS I suggest that you subscribe to [aprs-fl@tapr.org](mailto:aprs-fl@tapr.org) and join us. There are plenty of people on-line that can help if help is needed!

## APRS Tracks: RELAY, WIDE and Other Paths

Stan Horzempa, WA1LOU  
One Glen Avenue  
Wolcott, CT 06716-1442  
stanzepa@nai.net

The APRS-SIG is one of the mailing lists maintained by TAPR and, as its name indicates, it deals with topics related to APRS. If you are on the Internet and APRS-active, consider subscribing to APRS-SIG. It is one of the most active TAPR mailing lists and it contains a wealth of information that is useful to all APRS users, veterans and novices alike.

One of the most bewildering facets of APRS is how to set the path for your unconnected (unprotol) packets. It sometimes seems that there are as many opinions as to how to set your unprotol path as there are APRS users. As a result, it is no surprise that the art of setting unprotol paths is often the topic of conversation on the APRS-SIG.

Whenever the topic arises, different opinions are bandied about, but the conversation usually ends with a succinct message from the father of APRS, Bob Bruninga, WB4APR, which sets everyone straight. Bob's messages are usually very instructive and informative, so I thought I would share some of them with you. Hopefully, this will clear up some of the questions you have had about setting the path for your APRS unprotol packets.

### Just Say No to WIDE,WIDE,WIDE

APRS-SIG member 1 opined: First, regarding the WIDE,WIDE,WIDE. There are times when a station could be in the middle of a string of WIDEs...

APRS-SIG member 2 opined: Got to agree with you 100%. For example, my station is at the center of a three pronged system: a WIDE to the north, four WIDEs to the east, and two WIDEs to the south. A path of KF4FOH-10,WIDE,WIDE sends the packets in all three directions with KF4FOH-10 being my local WIDE. There is no other way to do it.

WB4APR replied: Yes there is and it is better. If you used WIDE,WIDE,DIGI3,DIGI4, that would hit all six digipeaters and you would avoid the multiple duplication of the three WIDE,WIDE,WIDE path you are now using (the DIGI3 and DIGI4 are the third and fourth digipeaters to the east). DIGI-10,WIDE,WIDE is the same as WIDE,WIDE,WIDE since all WIDEs after the first can still be re-duplicated by the first digipeater. Also, your path would need DIGI-10,WIDE,WIDE,WIDE to hit the fourth WIDE to the east, and this is in effect the same as WIDE,WIDE,WIDE,WIDE! In addition, if you hit two or more WIDEs directly with your initial packet, then the path could possibly be shortened even more!

There is nothing absolutely wrong with any chosen path, but it takes an understanding to use them appropriately and creatively.

But, APRS-SIG member 3 opined: There are three digipeaters within 40 miles of each other that I can hit, so I use the closest (most reliable) one as the first hop in my path! No way is this the same as using WIDE,WIDE,WIDE!

WB4APR replied: Wrong, as a general rule. If you are surrounded by three WIDEs and can hit all three, then VIA a single WIDE will hit all three at once! Defining the first one by its call sign wastes a hop and only mildly solves the multiple duplication problem if you are going further.

There are no absolute rules. Every path must be tailored to each station's situation only. But, if you can hit more than one WIDE direct, then it is frequently a good idea to start with WIDE to get your packet initially launched in two or more directions at once. Once you get beyond two WIDEs, then you need to fine-tune the path.

If you need to go three or more hops in two directions, fine-tune the path in one direction, say, WIDE,WIDE,DIGIA,DIGIB,DIGIC. Use the OPS-DIGI-ALT command to set an alternate path of WIDE,WIDE,DIGIX,DIGIY,DIGIZ for use 50% of the time.

### An Example

One APRS-SIG member presented the following example of an APRS network:

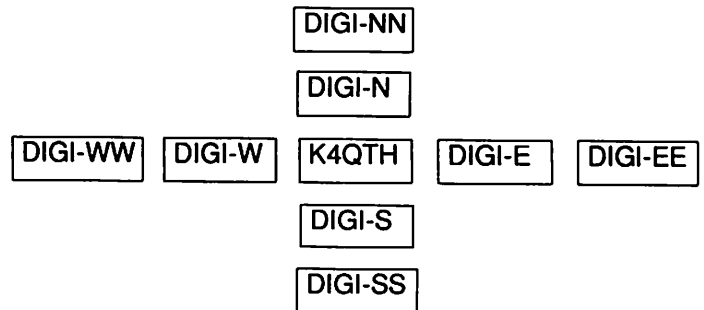

**Scenario 1: The inner five stations can all hear each other.**

**Question:** What happens if K4QTH uses an unprotocol path VIA RELAY,DIGI-W,DIGI-N,DIGI-E,DIGI-S,WIDE

**Answer:** K4QTH's packets go in a big circle! Four local copies, then DIGI-S sends it once via WIDE for four more copies for a total of nine packets. The only second tier digipeater to repeat it is DIGI-SS. Each packet was 28 characters longer than if K4QTH had used a path of WIDE,WIDE. Then all eight digipeaters would repeat

it once. The inner ring of digipeaters may repeat it twice, but hopefully these packets all collide at the same time and only take up one time slot.

**Scenario 2: The inner five stations all hear their neighbors, but not across the center, i.e., DIGI-E does not hear DIGI-W.**

Same questions... Same answers

**Scenario 3: The inner four digipeaters cannot hear each other.**

Same questions... Same answers

**Scenario 4: Add K1QTH, K2QTH, K3QTH to the center region between DIGI-W and DIGI-E.**

**Question: What happens if K4QTH beacons VIA RELAY?**

**Answer: All three stations and four digipeaters digipeat it at once (nine packets total). Since everyone heard it in the first place, it gets through.**

**Question: What happens if K4QTH beacons VIA RELAY,WIDE?**

**Answer: Total bedlam as all three stations and four digipeaters digipeat the RELAY, then all four digipeaters digipeat the eight resulting WIDEs. Then, the second tier also digipeats it for a worst case total of 73 packets (1 + 8 + 8\*8).**

Notes:

1. Non-isolated stations should not use RELAY at the beginning of their path.
2. If they all hear each other, then use no digipeaters.
3. If they all don't hear each other, then use VIA WIDE.
4. If you want to go out to all digipeaters, use WIDE,WIDE.
5. Never use WIDE,WIDE,WIDE or RELAY,WIDE,WIDE. With perfect collision avoidance, this results in a total of 149 packets (1 + 4 + 4\*4 + 16\*8).

**Question: K4QTH receives this packet: K9QTH APRS,WIDE,WIDE\*:\*APRS? What digipeaters passed this report?**

**Answer: Nobody knows. K4QTH probably received it lots of times, too.**

### May Your Paths Be Efficient

If you are in southern New England, anywhere east of downtown Wolcott, you can find my APRS digipeater station (WA1LOU-15) on 145.79 running some flavor of APRS 24 hours per day. Send me a packet and say hello. Good-bye, until then.

## Keeping Electronics Cool in the Sun

Bob Bruninga

bruninga@nadm.navy.mil

While building a GPS unit for mounting on my dashboard and noting the coming summer months, I looked up the difference in absorption and emissivity for aluminum, black paint, and white paint. Satellite builders are well aware of these facts, but many of us landlubbers are not.

It turns out that aluminum will get **30 times** hotter than white paint! (in a vacuum).

The following table is for a vacuum and accounts for radiative effects. It does not account for convective or conductive (air) cooling.

	Absorbtion	Emissivity	Ratio	Temp C
Aluminum	.4	.03	11:1	400
Steel	.6	.4	3:2	150
Black Paint	.9	.9	1:1	110
White Paint	.25	.85	1:3	72

Most people are aware that black gets hotter than white, but the fact that bright, reflective, shiny *aluminum gets 10 times hotter than black* is a surprise to most people.

So, if it sits in the sun, paint it white! If you don't believe this, put an aluminum baking sheet in the sun. I baked my first roof mount GPS stand alone tracker thinking that the upside down baking pan would reflect the sun. **WRONG!** Painted it white and it is now as cool as a cucumber.

The difference in aluminum is the poor emissivity at infrared. It can't radiate the heat away.

## Totally Accurate Clock (TAC)

Tom Clark

clark@tomcat.gsfc.nasa.gov

Regarding the article in the last issue on the *Totally Accurate Clock - Version 2*. Although the basic description is OK, the schematics of the TAC-2 are not entirely correct. They were an earlier version of the design before I stripped a lot of stuff off the printed circuit board. They show one more RS-232 input port than is on the final board, one more chip than was actually used, and they show a switching supply when we actually used a dirty, simple 78xx.

---

## Some news from the WLAN front

Barry McLarnon, VE3JF  
bm@lynx.ve3jf.ampr.org

I was recently at the IEEE MTT Microwave Symposium in San Francisco, and while there, attended a workshop called "Wireless LAN - What's Next?" Here's a few tidbits I picked up.

The market for Wireless Local Area Networks (WLAN) has been very slow to develop — one speaker estimated that the current market is less than 10% of what had been projected in 1992, and the market has turned out to be "vertical" rather than "horizontal." Although cost and performance issues are certainly factors, there was general agreement that lack of user education on what WLANs are all about has been a major impediment to expanding the market.

The 802.11 standardization effort continues to lurch along... latest estimate is that the committee will get down to serious voting around November. In general, I got the sense that the outlook for 802.11 is pretty gloomy. Most insiders seem to be convinced that the standard won't result in hardware from different vendors that will inter-operate. About the best that can be hoped for is that the common air interface will result in "RF coexistence" between different products, i.e., they will share the spectrum gracefully - but even this objective is undermined by the fact that the standard will allow both DS and FH products. One person involved in the process said 802.11 was "not a good standard", "not technically great", "complicated", and "hard to implement". Sounds good, eh?

There was quite a bit of discussion about the prospects for higher-speed products. A representative of Clarion in Japan said that they will soon introduce a 10 Mbps 2.4 GHz DS product in the US... no details on pricing, etc yet. Harris is also working on a 10 Mbps chipset. There was some mention of the developing HIPERLAN 20 Mbps (some documents say 25) standard in Europe (see <http://www.etsi.fr/ecs/reports/stateart/bourin.htm>). The FCC NII/SUPERNet NPRM (<http://www.fcc.gov/oet/info/nii5ghz.html>) may pave the way for HIPERLAN at 5.2 GHz in the US.

A scheduled speaker from Xircom was a no-show... apparently Xircom is scrapping its Netwave product and getting out of the WLAN business.

Elsewhere at the conference, there was an interesting keynote address from FCC chairman Reed Hundt (videotaped, since he was called to some hearings and couldn't make it to the conference), who talked about the FCC's "flexible, market-oriented approach to the use of spectrum." His talk was peppered with phrases like "no

government micromanagement" and "let the market pick the technologies." Also speaking (in person) was Mike Marcus of the FCC Office of Engineering and Technology, who I'm told was the prime mover behind establishing unlicensed ISM band operation in the US. An audience member attacked the FCC's declining interest in enforcement, stating that the ISM bands were becoming a shambles because the rules were being openly flaunted. He gave an example of a company in Nevada who is advertising a digital video WLAN product for unlicensed ISM band operation which has 2W into a 27 dBi gain antenna - 1KW ERP! Marcus replied that "enforcement doesn't make friends," and that increased enforcement wasn't likely to happen unless there was a strong push from the grassroots level for it... he did mention that an 800 number was being established to field complaints, though.

I suppose that this atmosphere of deregulation bodes well for increased use of SS in the amateur bands... on the other hand, a "market-oriented" approach to spectrum management doesn't sound too encouraging for the future of amateur radio, does it?

---

## Wireless Telecommunications Bureau Announces Revisions to Web Pages

The Wireless Telecommunications Bureau has expanded and improved its World Wide Web pages to provide more comprehensive information on the Bureau's activities and services and allow easier access to the information already available on line. Among the important changes:

New information on the Office of Operations in Gettysburg has been added. The links developed by Office of Operations' Licensing and Customer Services Divisions include extensive information on land mobile and microwave services, such as frequently asked questions on licensing issues, information on status of applications in the microwave services, access to forms and staff members, links to information sources outside the Commission, and other useful information. In addition, the new pages also include general information on issues handled by the Consumer Assistance Branch.

Many new links have been added from the radio service pages to related information. The home page has been redesigned to make finding information easier, and an organizational listing has been added that contains links to the various offices within the Bureau, including the Office of Operations - Gettysburg.

The Wireless Telecommunication Bureau's Home Page can be reached at <http://www.fcc.gov/wtb/wirehome.html>. To access the information on the Gettysburg pages follow the link to: Office of Operations - Gettysburg.



## Grid Square Code

Tom Clark, W3IWI  
clark@tomcat.gsfc.nasa.gov

Someone asked for Grid Square generation code. Here is the QBASIC code I use in my SHOWTIME software that allows certain GPS receivers to be used as very high accuracy clocks.

In this code, AvgLon/AvgLat are your Longitude and Latitude in decimal degrees, with positive East Longitudes and Negative West Longitudes (i.e. my Longitude here in Maryland is -76.85 degrees). Also note that the temporary variable v& is a long (32 bit) integer.

Normally I would have reported my grid square as FM19 or FM19me, but this code generates the string FM19me.75 meaning I am 0.7 of the way between FM19me and FM19ne, and midway between FM19me and FM19mf.

Here is executable code for you to test the routine.

## TAPR Group Purchase: PC-DSP and PC-SIM for Windows

For the past several months, the subject of digital signal processing has been discussed on the TAPR DSP-93 and HF-SIG e-mail lists. Software designed to facilitate the further learning and modeling of DSP entities has also been discussed (PC-DSP). Mention was made of a DSP course utilizing a text and a program called PC-DSP. The text is aptly named *Digital Signal Processing-A Laboratory Approach Using PC-DSP* by Oktay Alkin, PhD.

Jim Kauten, KO4RQ, checked with PC Solutions, the developer of the software, and it was discovered that a Windows version is available. There are versions available for Win 3.1x, Win NT, and Win 95.

After discussion with PC Solutions, they are willing to give a volume discount if there is enough interest. Jim announced the offer several weeks ago and approximately 30 people expressed an interest. Based on this interest TAPR will do a group purchase.

```
'This code adds one more level of precision to the Grid Square than is
'normally reported. Here at W3IWI, my coordinates are
  AvgLat = 39 + (11.3 / 60)           '39d 11.3 N
  AvgLon = -(76 + (56.1 / 60))       '76d 56.1 W
  GOSUB GridSquare
  PRINT "Input: Lat ="; AvgLat; " and Lon ="; AvgLon 'Input numbers
  PRINT "GRID SQUARE = "; g$        'Should print FM19me.75
  STOP

GridSquare:
' On Completion, the string contains the augmented "Maidenhead"
' Grid Square as a 9-character string g$ like FM19me.75
',
',
' Remember that in QB, the "\" is an integer division and note that v&
' is a long (32-bit) integer
',
' First, do the Longitude
  v& = (AvgLon + 540) * 1000000 MOD 360000000 'Mask to integer millidegrees
  W1% = (v& \ 20000000) + 65 '20 degree, 65 makes A-Z ASCII
  W2% = ((v& MOD 20000000) \ 2000000) + 48 '2 degree, 48 makes 0-9 ASCII
  v& = ((v& MOD 2000000) * 6) \ 1000 'arc mins * 100
  W3% = (v& \ 500) + 97 '5 arcmin, 97 makes a-z ASCII
  W4% = ((v& MOD 500) \ 50) + 48 '30 arcsec, 48 makes 0-9 ASCII
' And the Latitude
  v& = (AvgLat + 90) * 1000000 'Integer Millideg
  L1% = (v& \ 10000000) + 65 '10 degree, 65 makes [A-Z]
  L2% = ((v& MOD 10000000) \ 1000000) + 48 '1 degree, 48 makes [0-9]
  v& = ((v& MOD 1000000) * 6) \ 1000 'arc mins * 100
  L3% = (v& \ 250) + 97 '2.5 arcmin, 97 makes [a-z]
  L4% = ((v& MOD 250) \ 25) + 48 '15 arcsec, 48 makes [0-9]
' Make the perscribed Maidenhead string
' Generate the "FM19" portion:
  g$ = CHR$(W1%) + CHR$(L1%) + CHR$(W2%) + CHR$(L2%)
' append the "me.75" portion:
  g$ = g$ + CHR$(W3%) + CHR$(L3%) + "." + CHR$(W4%) + CHR$(L4%)
RETURN
END
```

The cost of the PC-SIM and PC-DSP for Windows package (includes both programs) will be \$220.00 US (\*see note). Shipping and handling will be an additional \$6 for U.S. deliveries. The standard non-discounted price for the package is \$256.00, inclusive of s/h, from PC Solutions. The TAPR group purchase plan nets a savings of \$30.00 for each person involved in the purchase of the software package.

21 orders must be placed with Dorothy at the TAPR office before the purchase will be made. These are orders (i.e. check, money order, or Visa/MC). This is not a call to generate a list that will be contacted at some future time. As with past group purchases, monies collected for the purchase will not be deposited until the order is placed. The purchase does not include the text mentioned above.

### Overview

PC-DSP is an interactive, menu-driven software package used for: waveform synthesis using a variety of methods, basic signal operation, fast Fourier transforms, convolution and correlation, solution of difference equations, analysis and design of IIR and FIR filters, digital filter simulation and code generation, and power spectrum estimation using classical and modern techniques. Some key features of PC-DSP listed include: GNU PLOT support, code generation, macro compiler, dialog compiler, sound file support, data file formats, and compatibility with PC-SIM.

PC-SIM is described as a continuous- and discrete-time simulator that is used for time-domain simulation of systems described by block diagrams. It was designed to be a flexible and open-ended tool to allow simulation of a broad range of systems encountered in communications, signal processing, and control theory. Some of the key features mentioned include: pre-defined components, code generation, sound file support, and compatibility with PC-DSP.

Demo versions of both programs are available from the PC Solutions web site:  
<http://www.dspsolutions.com>.

Information regarding the software should be directed to Jim Kauten, MD, KO4RQ ([kauten@mindspring.com](mailto:kauten@mindspring.com)). Orders for software should be directed to the TAPR office. TAPR would like to thank Jim for his effort in organizing this purchase.

\* Note: There will be no 10% membership discount on this purchase.

## Standardized Test Methods for Data Radios

Burt Lang, VE2BMQ  
[burt@rocler.qc.ca](mailto:burt@rocler.qc.ca)

This is to announce the opening of a web site devoted to establishing a Standard Set of Test Methods for testing radios intended for data service.

<http://www.rocler.qc.ca/burt/>

The Data Radio Standard Test Methods project was started 2 years ago and was presented at the 14th ARRL Digital Communications Conference in Texas in September 1995. At the conference, it was received with great interest. The proposed test method documents were finished and sent to selected organizations for review at the beginning of this year. I have now completed the transfer to the Web.

Warning: The documents are quite technical and don't have glitzy graphics or animation. Nor is the site just a bunch of links to other sites. It is just pure original technical documentation.

I welcome comments and constructive criticism. Bear in mind as with any new web document, that there are probably numerous minor bugs in the HTML markup that I have not yet detected. Also in the next few weeks, it will be undergoing frequent refinements.

Project Slogan:

*Let's Put the Radio back in Packet Radio!*

### TAPR Member's Mug

TAPR announces a new mug. This 11oz white Porcelain Mug has TAPR logos in both Black and Microwavable Gold. TAPR hasn't had a mug in a long time, so get your special TAPR mug now!



## Nominations Sought for TAPR Board of Directors

Tucson Amateur Packet Radio is incorporated in the State of Arizona as a non-profit scientific and educational institution. It is recognized by the IRS as a 501(c)3 tax-exempt organization for these same purposes. TAPR is governed by a 9-member Board of Directors. Each member of the Board serves a three year term. Every year three positions are up for election.

Board members are expected to attend two board meetings held in conjunction with the Dayton Hamvention and the ARRL and TAPR Digital Communications Conference. They participate in the decision-making process and provide guidance to the officers. They receive no pay and must defray their own expenses to attend meetings. Board members should be prepared to be active in the continuing Board deliberations, which are conducted via the Internet. Active participation in TAPR activities by Board members is important to the furtherance of the objectives of TAPR. The officers of TAPR are elected by the members of the Board at the annual Board of Directors meeting.

The current members of the Board of Directors and the expiration dates of their terms are:

*Greg Jones, WD5IVD	1997	President
*John Koster, W9DDD	1997	
*Mel Whitten, K0PFX	1997	
John Ackemann, AG9V	1998	Vice President
Jim Neely, WA5LHS	1998	Treasurer
Barry McLarnon, VE3JF	1998	
Steve Bible, N7HPR	1999	
Gary Hauge, N4CHV	1999	
Bob Hansen, N2GDE	1999	PSR Editor

Nominations are now open for seats expiring in March 1997 (marked with an asterisk).

To place a person in nomination, please remember that he or she must be a member of TAPR. Confirm that the individual is willing to have their name placed in nomination. Send that person's name (or your own if you wish to nominate yourself) along with your call and their call, telephone numbers, mailing address, and Internet address. The person nominated should submit a short biographical sketch to be published along with the ballot.

Nominations and biographical sketches should be submitted to the TAPR office no later than January 15th, 1997.

Ballots will be mailed with the next PSR. We are considering using some type of Internet ballot, so read your ballot instructions carefully. Results will be announced on March 30th, 1997.

Responsibilities of a board member include:

1) Attendance at both board meetings each year.

2) Regular participation with the continuous session of the board (currently held over the Internet). Typically this requires a minimum of 3 hours a week, although sometimes much more is required during active board discussions.

3) Participation with TAPR projects as volunteered. Board members, while not required, are involved with various project management, ongoing organization and/or supervision/liaison positions. Active board participation with various projects make many of the most important projects and tasks possible. Board members are expected to take an active part in TAPR in some form.

All nominated members will be placed on the ballot and the highest vote receivers will be placed in the open board positions. Two Board meetings in 1997 will be held. One will be during the Dayton Hamvention and the other during the ARRL and TAPR Digital Communications Conference. All directors shall serve for a term of three years.

## Kit/Publication Update

### AN-93: A PC Modem for HF

Good news. The correction daughter board should be at the board shop on September 30th and should then be available sometime the end of October. We plan on ordering the interboard connector that week as well so that we can have it in about the same time as the correction board. All that is left to do is to round up the docs from Brian Straup, NQ9Q and his tuning software, build one or two more up to test the docs and then get these things out the door. If you have had an AN-93 on order for more than six months, expect a surprise with your kit as a thank you for the wait. Really looking forward to getting this board shipped and with no major snags this kit will be shipping.

### TUC-52: Generic Microprocessor Board

The TUC-52 development group is again in gear and working towards having at least the METCON-2 available around Dayton next year. Beta board should be run sometime in the next few months along with the alpha personality boards. Probably plan on a big writeup in the next issue or two as the various personality boards are designed and developed.

### TAC: Totally Accurate Clock

The TAC development group is pressing forward with the alpha boards and by the end of October should be working on developing documentation and looking to see if the board needs any correction. TAPR should be looking at having a TAC kit available as soon as the documentation and any possible errors in the board are corrected. This looks like an exciting kit and a full description of the kit should be

available in the next issue describing all the various modes and what GPS units it supports.

### DAS: DTMF Accessory Switch

DAS kits still are selling. Should be looking at another run of boards sometime the first of next year, so that we have another 100 kits to sell.

### TNC-95: Plugin TNC for PCs

Development on the TNC-95 continues. Hardware bugs are being found and stepped on. Currently a version of TexNet code is operational on two of the alpha boards. We hope that as soon as a corrected board can be placed in Howie's hands, we can get 1.1.9 ported over to the unit.

### Books

Tom McDermott, N5EG, Wireless Digital Communications: Design and Theory should be in from the printers and binders sometime in November. The price has been set at \$39.99. You can find a complete table of contents on the TAPR web page under the publications link. Dorothy is taking orders.

Mel Whitten, K0PFX, is concluding his work on the 9600 Baud Land Mobile Modifications book. A section on 9600 baud full duplex repeaters is now planned to be added to the book. Target will be the first of the year for going to the printers.

TAPR 1996 CD-ROM sales have been brisk. The board decided not to do an additional run of the 1996 release once it is sold out. That the effort would be placed on doing a new 1997 edition for either the first of the year or before Dayton with several enhancements to help the end user who purchases the disk. Improved interface and an easier to read, and search, mail archives will be the focus.

"Amateur Spread Spectrum" (title to be determined) being actively written by Steve Bible, N7HPR, should be available in some draft form for comments soon. Keep an eye on tapr-bb for an announcement. Since Steve's schedule is sometimes hectic as an active naval officer we will get this book into production as soon as Steve has it ready.

Networking Without Wires: Amateur Radio TCP/IP being developed by John Ackermann, AG9V, is at least two chapters complete with another chapter due shortly and one more chapter being planned for the final book, which will be a section on Linux. Goal will be to have it in print for Dayton.

James Wagner has approached TAPR about making his Packet Radio books available. We should be talking to James in the coming months about doing this. This book would be a good fill-in to our current *Packet Radio: What? Why? and How?* publication.

## Board of Directors Meeting Minutes - Spring 1996

Dayton, OH - 16 May 1996  
(Edited for Publication)

The meeting was opened at 08:00 am. Members present were: Greg Jones, Jim Neely, John Ackerman, Barry McLarnon, John Koster, Mel Whitten, Steve Bible, and Gary Hauge.

Greg opened the meeting with the following subjects:

- WEB Server - We will be on a T-1 network soon.
- SIGs - All groups have shown an increase in attendance.
- Spread Spectrum - In work
- Manufacturers - No current interest
- Membership - Has declined over the last year. We will start advertising again.
- DCC - Agreement reached.
- 9600 baud kit - Boards will be returned to the office for modification and trace cutting.
- Dinner Facilities - The facilities are excellent and we will visit prior to the dinner.
- Office Report - Very Busy, E-mail orders are very good.

Secretaries Report - Gary H.

Report was read and accepted with minor corrections.

Treasurers Report - Jim N.

Report was read and noted that the Cash Flow is down this year.

Publications -

Mobile LAN Book in the works, Mel W. will review

Tom McDermott's book almost done  
John Ackermann's book near completion.

Election of Officers

John Ackermann conducted the board election process.

- President - Greg Jones  
Nominated by: John Ackermann  
Seconded by: Mel Whitten
- Vice President - John Ackermann  
Nominated by: Jim Neely  
Seconded by: Mel Whitten
- Secretary - Gary Hauge  
Nominated by: Jim Neely  
Seconded by: Barry McLarnon
- Treasurer - Jim Neely  
Nominated by: Greg Jones  
Seconded by: Mel Whitten

Voting was by acclamation, unanimous.

Old Business:

- ARRL DCC Update - \$500.00 scholarship from TAPR DCC 1997, interest from New Jersey area.  
Software Library - New librarian, Allen Finne

New Business:

- DSP - Sales down from last year but we will do another 50 kits.
- TNC-95 - John Koster is working
- TUC-52 - Paul Newland, Alpha boards are ready, minor changes in work, should be ready by end of summer.
- AN-93 update - corrections in work, 35 boards on order.
- 9600 Modem - Greg and Mel are working on changes, 18CV8s are being changed to 16V8s.
- PAL Images - Motion to release the code.  
Motion by: Jim Neely  
Second by: John Koster  
Passed
- Totally Accurate Clock - Tom Clark has approached Greg about TAPR kiting.

Motion to pursue Tom Clark on his clock.

Motion by: John Ackermann

Motion by: Jim Neely

Passed

- Noted lot of non-Ham interest in TAPR internet site.
- TAPR Foundation  
Motion by: John Ackermann  
Second by: Jim Neely  
Passed

John will do the research, Jim Neely will handle the finances and Greg Jones will do the marketing.

Membership

Printing expenses are on the increase. Greg proposed to increase the membership dues to \$20.00 US and Europe will remain at \$20.00.

Motion by: John Ackerman

Second by: Jim Neely

Approved

Advertising - Discussion on what kind and how much. No decisions made.

Real Audio Update - Approximately \$100.00 collected through donations. We will delay purchase for now.

Book on "Method of Evaluating Radios" - Barry/Greg

Discussion and decision to pursue discussions with author. Jim will research Postal costs.

Merchandising - Gary

Would like to consider shirts and hats for TAPR sales. He will pursue and report back to the board.

Spread Spectrum, FCC and Attorney fees  
Discussed fees vs. value. We will continue the effort.

Regional Groups - Discussion on how to bring them into TAPR.

Meeting was adjourned at 11:00pm

Gary N. Hauge, N4CHV

TAPR Secretary

## Board of Directors Meeting Minutes - Fall 1996

Seattle, WA - 20 Sept. 1996  
(Edited for Publication)

Meeting was called to order at 08:30.

Members Present:

Greg Jones, WD5IVD (President),  
Steve Bible, N7HPR,  
Bob Hansen, N2GDE,  
John Koster, W9DDD,  
Barry McLarnon, VE3JF,  
Mel Whitten, K0PFX.

Not Present:

John Ackermann, AG9V (V.P.),  
Gary Hauge N4CHV (Secretary),  
Jim Neely WA5LHS (Treasurer).

Guests:

Steve Stroh N8GNJ.  
Dwayne Hendricks, WA8DZP  
Frank Perkins, WB5IPM

Greg Jones requested that Steve Stroh take minutes for the meeting. The board approved the suggestion.

Reports:

The minutes from the Dayton Board meeting were reviewed. Bible motioned to accept minutes as printed, John Koster seconded, motion carried.

Koster motioned to accept treasurer's report as stated, Bible seconded, motion carried.

Packet Status Register Report.

Hansen discussed the number of pages for future publications. Discussion concerning advertising was held. TAPR still needs to locate someone that will bird dog potential advertisers for the PSR. No decisions about advertising have been reached.

Membership

Jones reported that membership as of the first of the year was 2173. TAPR is seeing about a 15% non-renewal rate. A full analysis of membership information will be conducted at the end of the year and reported. Membership overall seems to have stabilized at a little over 2000 members. Discussion was held on how to reach experimenters and also how to increase the number of articles

to target the membership to help membership retention.

Office

Jones reported that e-mail continues to be one of the fastest growing ways members are reaching the office. This has continued to help telephone costs. Overall, things are going OK.

1996 Sales Review

Jones reported that sales for this year are good and TAPR should be looking at a positive year overall financially. This seems to be on target with the budget forecast.

OEM Report and Prospects

Jones reported on the status of OEM prospects and deals closed since the last Board Meeting.

Publications Update

Whitten reported that he would try to have his sections of the 9600 Baud Land Mobile Modifications book completed by the end of November. We need to add a section on 9600 baud full duplex repeaters. Also need to add Bob Morgan's work on analyzing radios filters.

Jones reported that the *Wireless Digital Communications: Design and Theory* book is at the binders- probably have it by November.

Jones reported that the CD-ROM has been moving very well. May need to do an additional run by the end of the year. Many improvements planned for next version including mailing list archives converted to news groups so they can be read using web browser news reader function, index will be HTML, include some Linux. The board felt that an additional run should be held off in favor of just doing a new one and having more done to handle the volume. McLarnon will investigate conversion of mailing list to news group conversion.

"Amateur Spread Spectrum" (title to be determined) Being actively written by Bible. Will soon be ready to provide initial drafts for review via TAPR site, probably via .PDF.

*Networking Without Wires: Amateur Radio TCP/IP*. Ackermann has provided two chapters to Jones for layout and those were completed and returned. Will include Linux. Goal will be to have it in print for Dayton. This schedule will depend on John's recovery in the next few months after surgery.

Old Business:

Space Systems Academic Group (SSAG) HamKit

Bible called 2 weeks ago. PANSAT is still progressing. Digital Control System and modem working. Batteries identified, frame built, solar cells procured. PANSAT will use

SS on amateur frequencies. Original plan was to publish plans for ground station and not support it or provide kits. Steve put TAPR and SSAG together to possibly provide kits. Since then no movement has been made towards a possible TAPR kit. Just recently, the SSAG has decided to publish only, possibly as minimal as publishing protocols and not actually build a kit. Attraction would be that ground stations could be used terrestrially for SS development other than PANSAT access. Thus, this potential project will be put on hold until further information or movement is made from the SSAG side.

1997 Digital Communications Conference

The DCC committee will meet after this DCC and entertain proposals. Right now both NJ and MD groups have shown interest for the East coast in 1997. After that, 1998 DCC is Central, possibly Kansas City or Chicago. 1999 DCC tentatively proposed to return to Tucson, AZ. 2000 DCC tentatively proposed for Disneyworld, Orlando, FL. Some very preliminary discussions have taken place.

New Business:

Technical Projects

TUC-52 (PCON/METCON) is back on track. Alpha boards are working. Paul Newland and group are working towards having the MetCon available by Dayton time frame. A TrakBox alpha personality will be worked on in order to see if existing code can be ported to the new design.

AN-93. Brian Straup has been on hold regarding the board fix and the docs. Hope to have movement shortly after the meeting in the next week or two. Once the fix board is presented to the office we can get the board layed out and then cut within 4-5 weeks....then the 40+ kits on order can be shipped.

TAC (Totally Accurate Clock). Alpha boards at the board shop now. Should be available sometime shortly after this meeting for Tom to build up. Right now John Ackermann, Lyle Johnson, Steve Bible, and Paul Beckman will be working on the alpha boards. The next step will be to develop the docs as well as set a spec for the required enclosure.

9600 baud modem. We have been talking to TPRS about licensing their modem for kitting. The Texnet modem can be made compatible with TAPR and G3RUH modems with a minor filter change (actually degrades the performance of the Texnet modem). Both TNC2 and Texnet headers would be designed into the board so the board can be used in Texnet or systems compatible with the TNC-2's modem disconnect

header. Current TAPR modem would be marketed as full duplex bit regenerative 9600 baud modem (primarily for repeaters). Texnet modem would be licensed from Texas Packet Radio Society (TPRS) for a per-unit royalty. Koster along with Whitten will head up the development of the redesigned TexNet modem kit.

TNC95. The unit has TexNet code operational on it. Premise of use of Z80 again was that existing code could be ported, but little progress has been made with the porting effort. The use of a 386EX TNC has been proposed. Significant advantages include having enough processing power to use C language routines. An AX.25 implementation for the 386 has already been written. The 386EX has much the same I/O capabilities as Z80- little hardware conversion needed. A TNC, possibly as soon as 1998 could be based on a 386EX I/O engine and a very new and powerful Motorola 56303 DSP chip.

Motorola EVM. Motorola, working through Tim Baggett, would like to work with TAPR on future kits/evaluation boards. Benefit to Motorola is that TAPR is effective at getting kits/evaluation boards into hands of experimenters. Working with Motorola on DSP projects for experimentation has a lot of potential and more will be reported later. A meeting after the HF SIG is planned to discuss future direction.

GPS-20 kit. Have 100 units waiting on the power connectors and pins. The Paster-nack cables were more expensive than anticipated since we changed to a right angle MCX connector. Should TAPR be looking at another GPS engine? We will have Dorothy start taking another order of GPS-20, since we will probably sell the remaining units we have in stock before we ship with the power connectors.

BoD Travel

On behalf of Ackermann, budgeting for reimbursement of BoD travel expenses was proposed. Details are that the budget would be decided for the upcoming meeting, or year, and would be tied to the organization's income (lean year, no travel budget, etc.). A policy statement is probably needed- first class vs. coach, max. cost, etc. Bible motioned for Dayton 1997 BoD travel reimbursement to be 50% of room cost, and 50% of airfare not to exceed \$200. \$200 figure is for airfare alone. Koster seconded the motion, motion carried.

TAPR Specialty Items

The new TAPR mug is an experiment to see how well they sell, for how much. Labeling mugs for special events- DCC 1996 Seattle, etc. would probably enhance their salability. The board liked the mugs. T-shirts

were discussed, and the board decided not to do a silk screen version, primarily because of stocking and production run issues. The possibility will be examined to produce single quantities of knit, embroidered shirts with a stored logo. No stocking issues, would be ordered from vendor when TAPR receives an order. Custom made shirts basically based on preference. It was decided to make sure we had some type of shirt for Board members and those working the booth at Dayton.

**1997 BoD Elections**

Jones discussed possible electronic balloting via the TAPR Web site. A unique number would be printed on each PSR mailing label. TAPR members would access an electronic ballot on a BoD Election Web page. The unique number must be correct for the vote to be counted. The paper ballot could also be completed, and mailed as usual. Koster motioned to accept the plan to experiment with an electronic ballot, Bible seconded, motion carried.

**TAPR Monthly News Statement**

A monthly news report, equivalent to AMSAT News Service (ANS) is badly needed. Jones hasn't been able to find a

suitable person. Keep an eye out for someone who might be interested in doing this.

The board broke for lunch. Big thanks to Tina Stroh for a great lunch!

**National Science Foundation (NSF) Grant Status**

Dewayne Hendricks, WA8DZP, reported on the current status of the submitted NSF grant. All indications are that it was well received by NSF and Dewayne is confident that the Grant will be funded in FY97. A meeting with NSF is scheduled for 10/8/96. Hendricks will report after the meeting what the status is.

**RM-8737 and the TAPR SS STA**

Discussion of SS STA and related issues. Bible motioned to fund legal expenses for Petition for Rulemaking for Spread Spectrum rules change. Whitten seconded, motion carried. Some discussion of OEM possibilities for SS products took place.

**TAPR's Statement on Spread Spectrum Technology Development**

The statement was read and discussed. Neely's correction to remove 501(c)3 wording was mentioned. Koster motioned to adopt it with the correction of removing ref-

erence to 501c3. Bible seconded, motion carried.

**Organizations and Goals**

Jones lead a brief discussion regarding the current goals and directions. These were set at the last BoD meeting held in Tucson. The board still agrees that they meet the needs of the membership and that the organization seems to be working towards those goals and succeeding to deliver significant milestones.

Hansen motion to adjourn at 14:30 PDT. Respectfully submitted, Greg Jones, President

(Note: Minutes taken by Steve Stroh, N8GNJ, on the request of the board)

**Office Hours during Holiday Period**

The TAPR office will be closed from December 16th, 1996 to January 14th, 1997. Thus the last day of the office is December 13th with the office reopening on January 14th, 1996.

**TAPR Software Library**

Current as of 13 March 1996.

Disk numbers listed with an "A" are two-disk sets. All ftp filenames listed below should be preceded with "/tapr/software\_lib".

<u>Disk No.</u>	<u>Name</u>	<u>Version</u>	<u>ftp Filename</u>		
1.	APLINK	Ver. 7.01	/bbs/apl701.exe	14.	WINLINK Ver. 1.2 /bbs/wmlink12.zip
2.	AA4RE BBS	Ver. 2.12	/bbs/bb212.zip	15.	WA7MBL BBS Ver. 5.14 /bbs/mb1514.zip
3.	CBBS	Ver. 7.30	/bbs/cbbs73.zip	16.	WORLI BBS Ver. 18.05 /bbs/rli1805.exe
4.	EZPAC	Ver. 1.1	/misc/ezpac11.zip	17.	YAPP Ver. 2.0 /terminal/yapp.zip
5.	MONAX		/misc/monax.zip	18.	INTRO TO TCP/IP /tcpip/tcpintro.zip
	PRAFFIC	Ver. 2.05E	/misc/praf205e.zip	19.	LAN-LINK Ver. 2.32 /terminal/l1232.zip
	PACKHACK	Ver. 8	/misc/phack8.zip	20.	ARESDATA Ver. 1.6 /misc/aresdata.zip
6.	Ham Comm	Ver. 3.0	/misc/hamcom30.exe	21A.	MSYS Ver. 1.19 /bbs/msys119.zip
7.	TNC-2 Manual and EPROMS	Ver. 1.18A	/tnc/eproms.exe	22.	G8BPQ NODE Ver. 4.08a /switch/bpq408a.zip
			/tnc/hostmode.exe	23.	Utilities now on disk #8
			/tnc/tncdocs.exe	24.	THS Ver. 2.50 /terminal/ths.zip
8.	Text conversion Utilities			25.	VE4UB NTS Ver. 091891 /misc/ntsve4ub.exe
	7PLUS	Ver. 2.02	/utils/7plus20.exe	26.	NM1D DOSGATE Ver. 1.14 /misc/dosgate.zip
	LHA	Ver. 2.11	/utils/lha211.exe	27.	SV7AIZ BBS Ver. 4.51 /bbs/aiz451.exe
	PKARC	Ver. 3.6	/utils/pk36.exe	28.	TEXNET Ver. 1.72 /switch/tpns172.zip1
	PKZIP/PKUNZIP	Ver. 2.04G	/utils/pk204g.zip	29.	Intro To Packet Radio, A Tutorial 06-16-95 /misc/intropkt.zip
	R95	Ver. 4.0	/utils/r9540.exe	30.	MICROSAT Ground-station Software /sat/microsat.zip
	UUENCODE/UUDECODE	Ver. 5.40	/utils/uuexe540.exe		PB / PG / PFHADD / PHS
	ZOO	Ver. 2.10	/utils/zoo21.exe	31.	No Longer Available (see 38)
9.	ROSERVER PRMBS	Ver. 1.73	/bbs/rsvr173.zip	32.	PAMS-Personal AMTOR Mailbox Ver. 2.09 /bbs/pams209.zip
10.	ROSE X.25 SWITCH	Ver. 3.7	/switch/rzsw37.zip	33.	TNC-2 Z-80 Monitor Ver. 2.00 /tnc/monz80.zip
			/switch/rswd33.zip	34.	GIL (Graphics Interchange Lang.) Ver. 1.03 /misc/gil1-03.zip
11.	KA9Q NET	Ver. K36		35A.	PAKET Ver. 6.1 /terminal/paket61.zip
	Executable and Documentation		/tcpip/netk36ex.zip	36A.	F6FBB BBS Ver. 5.15 /bbs/f6fbb515.zip
	Source Code		/tcpip/netk36sr.zip	37.	TPK Ver. 1.82 /terminal/tpk182.zip
12.	WXN Weather Svr.	Ver. 5.11	/misc/wxn511.zip	38.	JNOS (Executables, docs.) Ver. 1.10M /tcpip/jnos110m.exe
13.	TNC1 CODE & TNC2 Notes		/tnc/tnc1src.zip		/tcpip/docs110m.zip
			/tnc/tnc2not.zip	39A.	JNOS (Source Code for 38) Ver. 1.10M /tcpip/jn110m.zip
				40.	SP Packet Ver. 6.50 /terminal/sp650.exe
				41.	TAPR Deviation Meter Source and Tools /misc/devmtr.zip
				42.	PCTOR/PC-PACTOR Ver. 3.02 /terminal/pctor302.zip
				43.	METCON ROM Code Ver. 1.07 /misc/metcon.zip

Orders for any of the above disks should be sent to the TAPR office. New submissions or updates should be sent to the software librarian c/o the TAPR office.

## Update on TAPR SS STA Participation

If you are a member of TAPR and want to participate in the TAPR SS STA, here are the minimum requirements:

- Stations will be required to maintain the highest standards in operational practices.
- Stations will be required to submit a report before the end of the STA that will be used in the final report.
- Stations must have a dependable Internet e-mail service so that information and discussion regarding the STA can be held.
- Stations must hold at least a Technician Class license.
- Stations must be aware that any transmissions conducted pursuant to the requested STA will be secondary in nature, and must cease immediately in the event of harmful interference.
- Stations must be a current member of TAPR.

An on-line application will be available on <http://www.tapr.org/ss> in the TAPR STA area that allows TAPR members to submit a request to participate. Applications will be reviewed by the STA holders. The STA holders can add and remove people from the list at their discretion. Addition to the list will happen on a periodic basis as allowed by the FCC.

## TAPR to offer 902-928Mhz SS Radio Group Buys in the Spring

In order to allow TAPR members, who might not be able to design and build their own SS equipment from scratch, TAPR will be doing a series of group purchases on a 115Kbps 900Mhz SS (Freq Hopper) radio for use under the STA.

TAPR has arranged a deal to purchase an existing Part 15 OEM Spread Spectrum module that can be used under the current TAPR STA.

TAPR hopes that eventually the rules change process will allow these types of commonly available radios to be used under Part 97 in the future. But, if the Part 97 rules don't change after the STA has been completed, these units can still be used under Part 15 rules....so any investment now will not be lost.

More details will be published on the TAPR Web page ([www.tapr.org](http://www.tapr.org)) as well as on the Spread Spectrum Page. An announcement will be made in the next PSR as well as posted to TAPR-BB when the purchases are available.

13. Publication Title		14. Issue Date for Circulation Data Below	
PACKET STATUS REGISTER		AUGUST 1996	
15. Extent and Nature of Circulation		Average No. Copies Each Issue During Preceding 12 Months	Actual No. Copies of Single Issue Published Nearest to Filing Date
a. Total Number of Copies (Net press run)		2300	2500
b. Paid and/or Requested Circulation	(1) Sales Through Dealers and Carriers, Street Vendors, and Counter Sales (Net mailer)	—	—
	(2) Paid or Requested Mail Subscriptions (Include advertiser's proof copies and exchange copies)	1900	2000
c. Total Paid and/or Requested Circulation (Sum of 15b(1) and 15b(2))		1900	2000
d. Free Distribution by Mail (Samples, complimentary, and other free)		250	250
e. Free Distribution Outside the Mail (Carriers or other means)		300	350
f. Total Free Distribution (Sum of 15d and 15e)		550	600
g. Total Distribution (Sum of 15f and 15c)		2450	2600
h. Copies not Distributed	(1) Office Use, Leftovers, Spoiled	50	50
	(2) Returns from News Agents	—	—
i. Total (Sum of 15g, 15h(1), and 15h(2))		2500	2650
Percent Paid and/or Requested Circulation (15c / 15g x 100)		77.55%	76.92%

16. Publication of Statement of Ownership  
 Publication required. Will be printed in the Fall 1996 issue of this publication.  
 Publication not required.

17. Signature and Title of Editor, Publisher, Business Manager, or Owner  
Dorothy Jones, Office Manager Date Oct. 2, 1996

I certify that all information furnished on this form is true and complete. I understand that anyone who furnishes false or misleading information on this form or who omits material or information requested on the form may be subject to criminal sanctions (including fines and imprisonment) and/or civil sanctions (including multiple damages and civil penalties).

### Instructions to Publishers

1. Complete and file one copy of this form with your postmaster annually on or before October 1. Keep a copy of the completed form for your records.
  2. In cases where the stockholder or security holder is a trustee, include in item 10 and 11 the name of the person or corporation for whom the trustee is acting. Also include the names and addresses of individuals who own or hold 1 percent or more of the total amount of bonds, mortgages, or other securities of the publishing corporation. In item 11, if none, check the box. Use blank sheets if more space is required.
  3. Be sure to furnish all circulation information called for in item 15. Free circulation must be shown in items 15d, e, and f.
  4. If the publication had second-class authorization as a general or requester publication, this Statement of Ownership, Management, and Circulation must be published; it must be printed in any issue in October or, if the publication is not published during October, the first issue printed after October.
  5. In item 16, indicate the date of the issue in which this Statement of Ownership will be published.
  6. Item 17 must be signed.
- Failure to file or publish a statement of ownership may lead to suspension of second-class authorization.



### Statement of Ownership, Management, and Circulation (Required by 39 USC 3685)

1. Publication Title PACKET STATUS REGISTER	2. Publication Number —-5419	3. Filing Date October 2nd, 1996
4. Issue Frequency QUARTERLY	5. Number of Issues Published Annually Four	6. Annual Subscription Price \$ 20.00
7. Complete Mailing Address of Known Office of Publication (Not printer) (Street, city, county, state, and ZIP+4) TUCSON AMATEUR PACKET RADIO P.O. Box 51114 Denton, Tx 76206-1114		Contact Person Dorothy Jones Telephone (817) 383-0000
8. Complete Mailing Address of Headquarters or General Business Office of Publisher (Not printer) TUCSON AMATEUR PACKET RADIO 8987-309 E TANQUE VERDE #337 TUCSON, AZ 85749-9399		
9. Full Names and Complete Mailing Addresses of Publisher, Editor, and Managing Editor (Do not leave blank) Publisher (Name and complete mailing address) TUCSON AMATEUR PACKET RADIO 8987-309 E TANQUE VERDE #337 TUCSON, AZ 85749-9399 Editor (Name and complete mailing address) ROBERT HANSEN - N26DE P.O. Box 1902 Elmira, NY 14902-1902 Managing Editor (Name and complete mailing address)		

10. Owner (Do not leave blank. If the publication is owned by a corporation, give the name and address of the corporation immediately followed by the names and addresses of all stockholders owning or holding 1 percent or more of the total amount of stock. If not owned by a corporation, give the names and addresses of the individual owners. If owned by a partnership or other unincorporated firm, give its name and address as well as those of each individual owner. If the publication is published by a nonprofit organization, give its name and address.)

Full Name	Complete Mailing Address
TUCSON AMATEUR PACKET RADIO	8987-309 E TANQUE VERDE #337 TUCSON, AZ 85749-9399

11. Known Bondholders, Mortgagees, and Other Security Holders Owning or Holding 1 Percent or More of Total Amount of Bonds, Mortgagees, or Other Securities. If none, check box  None

Full Name	Complete Mailing Address
/	

12. Tax Status (For completion by nonprofit organizations authorized to mail at special rate) (Check one)  
 Has Not Changed During Preceding 12 Months  
 Has Changed During Preceding 12 Months (Publisher must submit explanation of change with this statement)

Kits	Price	Qty	Total
DSP-93 w/ wall transformer (US)	\$430.00		
DSP-93 w/o wall transformer	\$420.00		
DAS (DTMF Accessory Squelch)	\$68.00		
AN-93 HF Modem	\$90.00		
TAPR 9600 bps Modem	\$80.00		
Bit Regenerator	\$10.00		
Clock Option	\$5.00		
PK-232 Modem Disconnect	\$20.00		
PK232MBX Installation Kit	\$20.00		
XR221 I DCD Mod.	\$20.00		
State Machine DCD Mod.	\$20.00		
State Machine DCD w/Int Clock	\$25.00		
METCON-I Telemetry/Control			
Voltage-to-Frequency module	\$30.00		
Temperature-to-Freq module	\$40.00		
A-D Converter	\$45.00		
Elapsed Time Pulser	\$35.00		

Firmware	Price	Qty	Total
32K RAM w/ TNC2 update docs	\$20.00		
TNC-2 I.1.9 w/KISS EPROM	\$15.00		
I.1.9 Commands Booklet (only)	\$8.00		
TNC-2 WA8DED EPROM	\$12.00		
TNC-1 WA8DED EPROM	\$12.00		
TNC-2 KISS EPROM	\$12.00		
TNC-1 KISS EPROM	\$12.00		
PK-87 WA8DED EPROM	\$12.00		

Publications	Price	Qty	Total
1996 TAPR CD-ROM	\$20.00		
Wireless Digital Communications	\$39.99		
Packet Radio: What? Why? How?	\$12.00		
BBS Sysop Guide	\$9.00		
TAPR's 94 Annual Proceedings	\$7.00		
TAPR's 95 Annual Proceedings	\$7.00		
PSR Set Vol 1 (#1 - #17 '82 - '85)	\$20.00		
PSR Set Vol 2 (#18 - #36 '86 - '89)	\$20.00		
PSR Set Vol 3 (#37 - #52 '90 - '93)	\$20.00		
NOSIntro, Intro to KA9Q NOS	\$23.00		
ARRL CNC Proceedings 1st - 15th	call		
Entire Set ARRL CNC 1st - 13th	\$110.00		

Other	Price	Qty	Total
TAPR 11oz Coffee Mug logo	\$11.00		
TAPR Badge	\$10.00		
3 1/2" Disk from TAPR Library	\$3.00		

Kit Code	Information
16	check with office on ship date, no discount
16	for international orders only, no discount
3	limited kits available. As seen in Dec 95 QST
3	limited kits available.
6	
1	used for regenerative repeater operation
1	used for regenerative repeater operation
2	simplifies connection of external modems
2	for installation of 9600 modem in PK-232MBX
2	
2	
2	For KPC2 or other TNC w/o I&X or 32X int dock
2	Metcon-1 kits no longer available.
3	Plenty of the Option Kits!
3	
3	
3	
2	
4	includes I.1.9 Commands booklet (below)
2	full TNC-2 command set for I.1.9
2	8 connect version for ARES/Data standard
2	
2	
2	
2	
4	ISO 9660. Over 400 Megs of stuff !
8	300+ pages w/disk by: Tom McDermott, N5EG
2	130 pages. TAPR's Packet Radio book.
2	60 pages. by: Barry Buelow, WA0RJT
2	Papers from the Annual Meeting (Tucson)
2	Papers from the Annual Meeting (St Louis)
8	
8	
8	
8	Ian Wade, G3NRW, TCP/IP over Packet Radio
8	Individual Proceedings, call for prices
144	10 Proceedings from 1981 to 1994
4	Logo in black and microwavable gold
0	include Name and Call for badge
0	\$3 per disk. See TAPR Software Library List



**Tucson Amateur Packet Radio**  
 8987-309 E. Tanque Verde Rd #337  
 Tucson, Arizona • 85749-9399  
 Office: (817) 383-0000 • Fax: (817) 565-2544  
 Non-Profit Research and Development Corporation

**November 1996**

www.tapr.org • ftp.tapr.org • tapr@tapr.org  
 Office Hours: Tue-Fri 9am-12pm, 3pm-5pm CT

Membership	Price	Number of Years	Total
United States	\$20.00		
Canada/Mexico	\$20.00		
International	\$25.00		

Renewal       New Member

**SubTotal**

**Membership 10% Discount**  
 Except were noted Member #: \_\_\_\_\_ (Place new if joining)

**Total Sales (Subtotal minus discount)**

**Texas Residents (7.75% tax)**

**Membership (New or Renewal)**

**Shipping and Handling**  
 For Total Kit Codes Between

<b>1 - 3</b>	<b>4 - 7</b>	<b>8 - 15</b>	<b>16 - 27</b>	<b>28 - 55</b>
Add \$3	Add \$4	Add \$5	Add \$6	Add \$7

Kit Codes above 55 or International orders must contact TAPR for amount.

**TOTAL Order Amount**

Charge my credit card (check one):

VISA     MasterCard

Acct. # \_\_\_\_\_

Expiration Date: \_\_\_\_\_

Signature on card: \_\_\_\_\_



Name / Call: \_\_\_\_\_

Street Address: \_\_\_\_\_

City / State / Zip: \_\_\_\_\_

Country: \_\_\_\_\_ Phone Number: \_\_\_\_\_

Internet E-mail: \_\_\_\_\_

**Subtotal:**  **Added Total Kit Codes**

All prices subject to change without notice and are payable in U.S. funds. Members receive 10% off on Kits and Publications. Please allow six to eight weeks for your order to be shipped. For specific information on kits, see Product Description flyer.